

SALES RELEASE:

TCMH 0450 for High Pressure Liquids & Gases

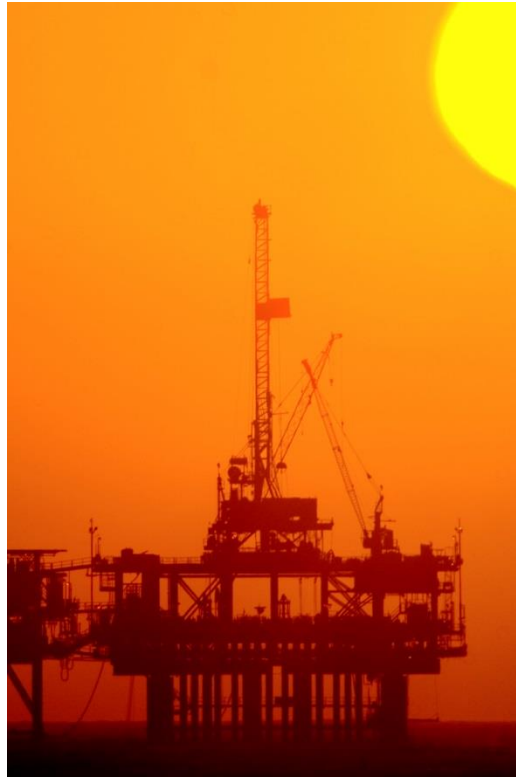

High Pressure Liquids

- Pressure Rating (Code)
 - TCMH 0450-HC-SPOS 15,200 psi (1,050 bar)
 - TCMH 0450-HC-SROS 10,000 psi (690 bar)
 - TCMH 0450-HC-SSOS 6,000 psi (414 bar)
- Flow Range 0.165-16.5 lb/min (4.5-450 kg/h)
- Flow $\pm 0.2\%$ of reading
- Mass Repeatability $\pm 0.1\%$ of reading
- Zero Stability $\pm 0.075\%$ of f. s.

NACE Compliance

- NACE MR0175/MR103

Mass Flow Meter

- Not available to date for Density and Volume Flow Measurement (under test)

High Pressure Gases

- Pressure Rating (Code)
 - TCMH 0450-HC-SPPS (or -SPMS) 15,200 psi (1,050 bar)
 - TCMH 0450-HC-SRPS (or -SRMS) 10,000 psi (690 bar)
 - TCMH 0450-HC-SSPS (or -SSMS) 6,000 psi (414 bar)
- **P** for 1.4404/AISI 316L = NACE compliant, **M** for HP160 = not NACE compliant
- Max. Flow rate see datasheet
- Flow $\pm 1\%$ of reading
- Mass Repeatability $\pm 0.5\%$ of reading
- Zero Stability 0.0165 lb/min (0.45 kg/h)

NACE Compliance

- NACE MR0175/MR103



Mass Flow Meter

- Not available to date for Density and Volume Flow Measurement (under test)

Operating Conditions – Process

(Customer specific pressure compensation curves on request)

- Medium Temperature -40°F to +212°F (-40°C to +100°C)

Operating Conditions – Environment

- Ambient Temperature -40°F to +158°F (-40°C to +70°C)
- Relative Humidity max. 95%

Output Signals

- Analog
 - Two 4-20 mA passive two-wire, galvanic free
 - Accuracy $\pm 0.05\%$ of f. s.
 - Temperature drift 0.05% per 10 K
 - Load $< 620 \Omega$ (with 24 V supply)
 - Output value programmable
- Frequency/Pulse
 - 5-10,000 Hz/Active Push-Pull for flowrate
- Status
 - Push-Pull programmable

Input Signals

- Control Input
 - 0/24 V DC
- Analog (optional)
 - 4-20 mA active for passive
 - Two-wire-pressure sensor
- Interface
 - RS485 RTU (Modbus)
 - HART[®]

Ex-Certifications

- cCSAus (Ex1) Class I, Division 1: Group A, B, C, D, T2 to T4
- ATEX (Ex) Zone 1: Group IIC T2 to T4
- ATEX (Exn) Zone 2: II 3G Ex nA IIC, T2 to T4 Gc
- IECEx (Ex) Zone 1: Group IIC T2 to T4
- ATEX + IECEx + cCSAus
triple approval (Ex3) Zone 1: Group IIC T2 to T4+
cCSAus: Class 1, Div. 1: Group A, B, C, D, T2 to T4



- Pressure stress variation Δp
- $P_{\max} = 17,404 \text{ psi (1,200 bar)}$
- $P_{\min} = 145 \text{ psi (10 bar)}$
- Frequency $f = 6 \text{ Hz}$
- 1,000,000 load cycles were given
- The pressure directive 2014/68/EU recommends for dynamic pressure testing of high pressure tanks, a test pressure of 1.25 times of the nominal pressure in bar. Limit of dynamic pressure test facility was at 17,404 psi (1,200 bar).
- Final internal test procedure comprises a 29,000 psi (2,000 bar) static pressure test.
- All tests passed successfully.

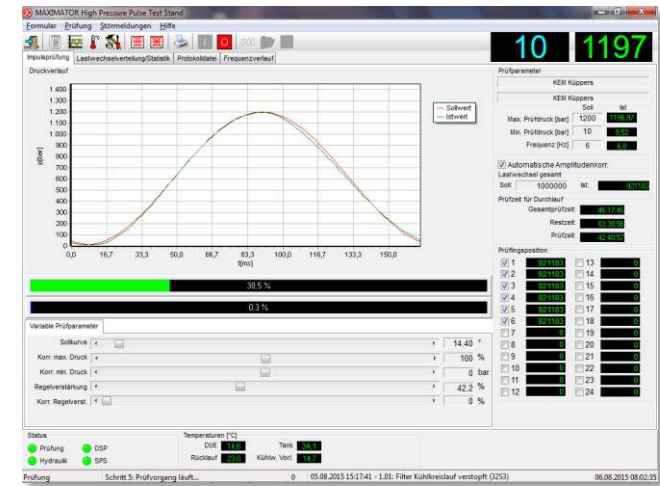
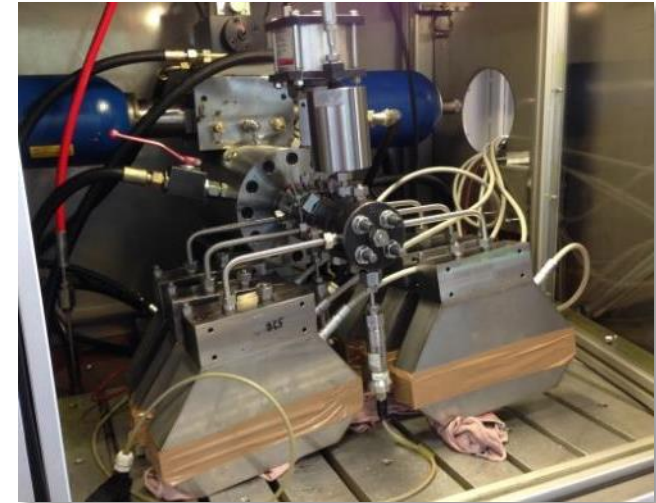

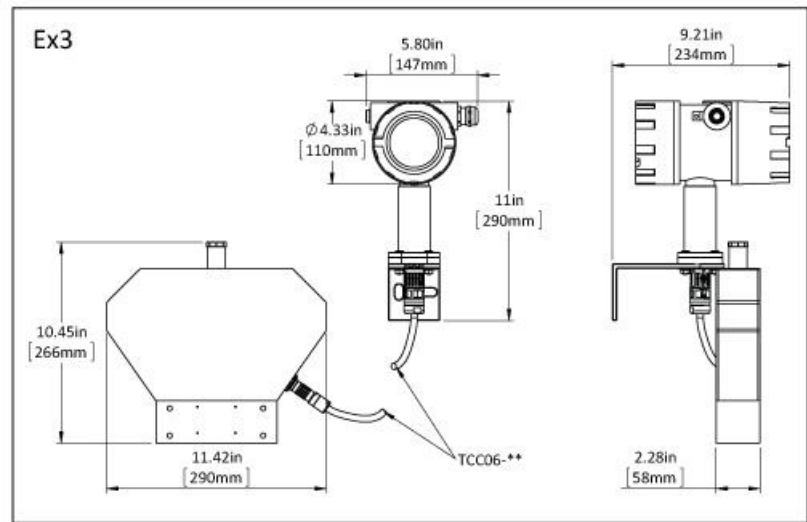
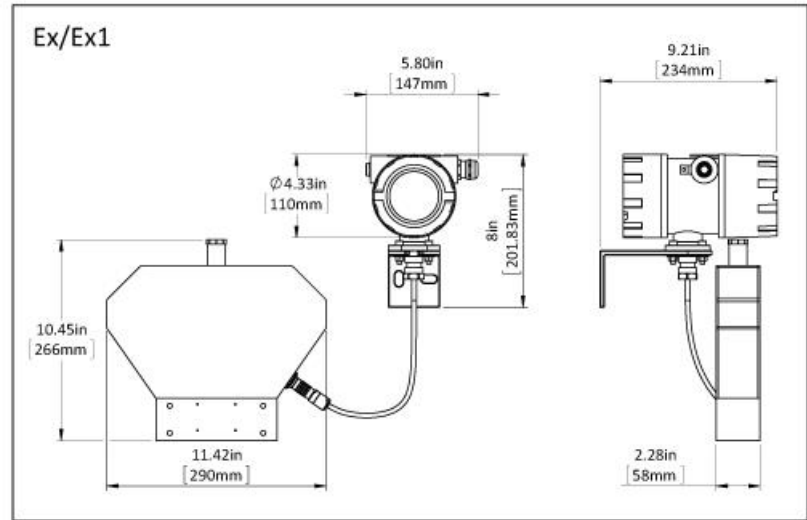
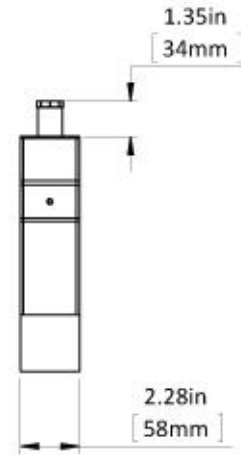
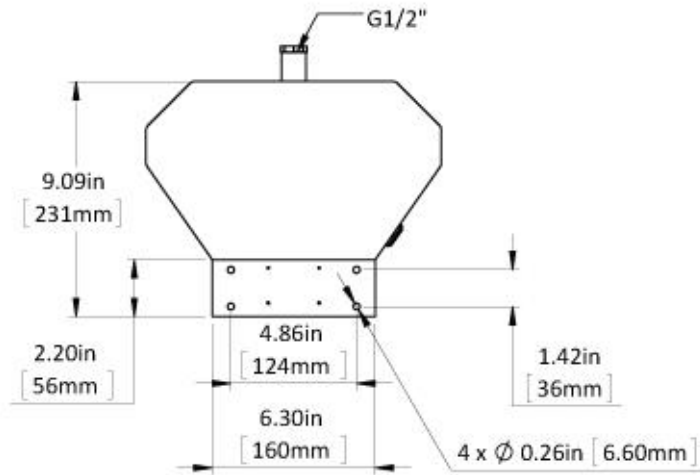
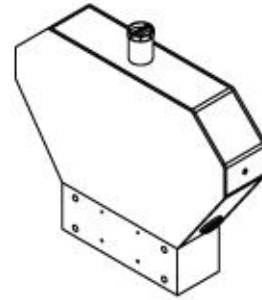
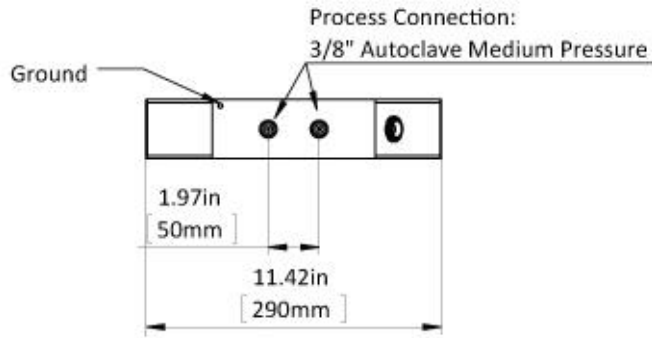

- General Flow Control
- Chemical Injection
- High Pressure Gas Dispensing
- Additive Dosing
- Test benches for high pressure injections (Gas & Liquids)

Manufacturer	Meter Type	Design Pressure	Qmax	Accuracy o. r.	Available
AW-Lake / KEM	TCMH 0450	15,200 psi(1,050 bar) 10,000 psi (690 bar) 6,000 psi (414 bar)	16.5 lb/min (450 kg/h)	0.2 % Liquids 1.0 % Gas	Yes
MM	HPC010P	15,000 psi (1,034 bar)	3.7 lb/min (100 kg/h)	0.2 % Liquids	No
Rheonik	RHM04PH	12,618 psi (870 bar)	22.05 lb/min (600 kg/h)	0.2 % Liquids 0.5 % Gas	Yes
Heinrichs	TM various	up to 15,200 psi (1,050 bar)	Various	0.2 % Liquids 0.5 % Gas	Yes

others

OVAL

Bronkhorst

Brooks



First stage with *LEMO Connector
*Material: Chrome plated brass shell

Linde Engineering

High Pressure Hydrogen

Pressure rating: 15,200 psi (1,050 bar)

Operating pressure: 290-12,690 psi (20-875 bar)

High Pressure TRICOR® Coriolis Mass Flow Meter for Chemical Injection Applications



High Pressure Chemical Injection

In the oil & gas industry, chemical injection is widely employed to prevent scaling, corrosion or hydrate plugging in pipelines, pumps and other critical onshore and offshore assets.

Examples of chemicals include:

- Methanol to prevent hydrate formation
- Glycol (MEG/TEG) for gas dehydration

Typical Density and Viscosity Ranges

- 6.67 lb/gal (0.8-1.2 kg/l)
- 0.6-30 cSt or higher



Available Soon

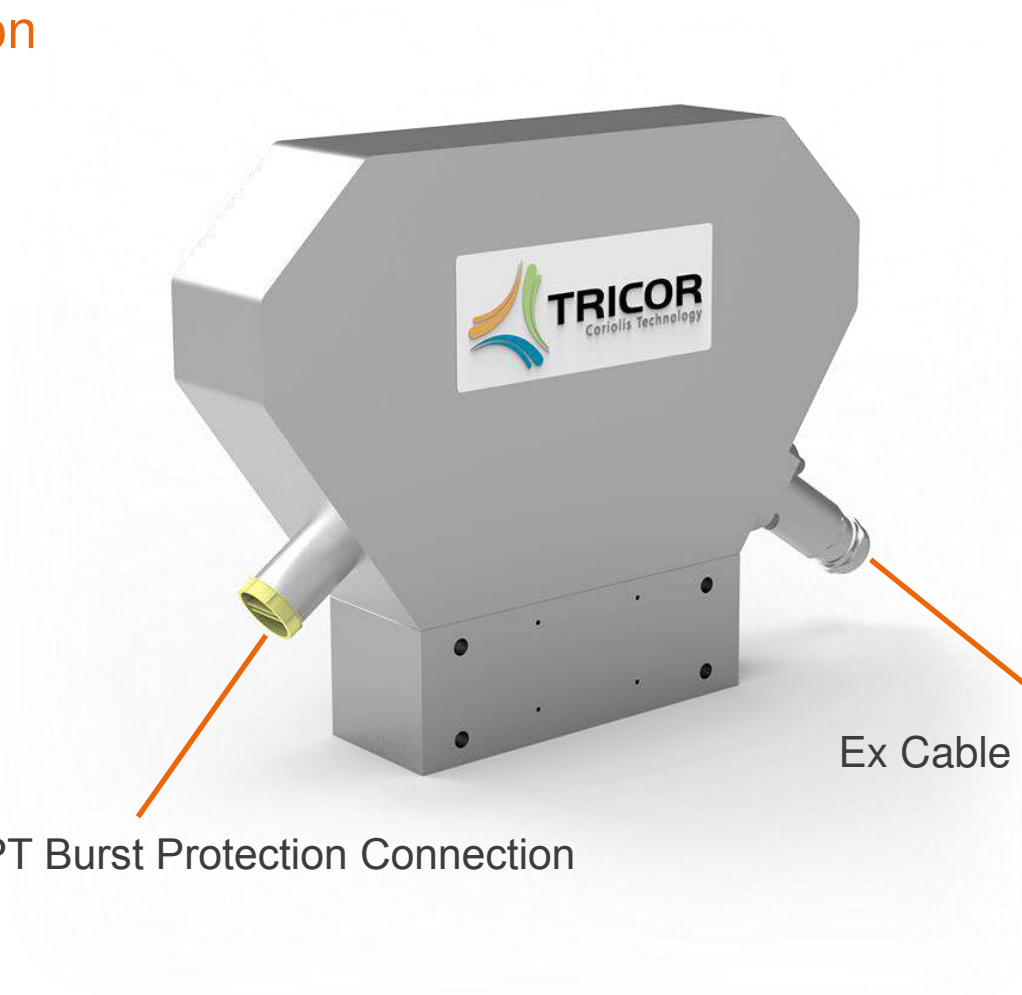

G 1/2" or 1/2" NPT Burst Protection Connection

Ex Cable Gland (316 L)

Datasheets

- [TCMH G 0450 F EN 160826 E001.pdf](#)
- [TCMH L 0450 F EN 160826 E001.pdf](#)

Manual

- In process

Sizing

- TCM_sizing program_2.4.exe (available on request)

Model Code Configurator

- PL TRICOR 2016_151215_E001.5.xlsm (available on request)

Website

- www.tricorflow.com

Take advantage of our strong Global Flow Solution Network with competences in a diversified line-up of flow measurement technologies.



North and South America

AW-Lake Company

2440 W. Corporate Preserve Dr. #600,
Oak Creek, WI 53154, USA
P: +1 414 574 4300

China

TASI Flow

Rm. 2429 Jin Yuan Office Building, No. 36
CN - BeiYuan Road, Beijing 100012
P: +86 10 520 037 38

Rest of the World

KEM Kueppers Elektromechanik GmbH

Liebigstraße 5
85757 Karlsfeld, Germany
P: +49 (0) 8131 59391-0

Singapore

TASI Flow Southeast Asia

1003 Bukit Merah Central #06-32,
Singapore 159836
UEN: T15RF0080G
P: +65 6274 1130