

MAINTENANCE GUIDE FOR THE JV-XXKG SERIES FLOW METER

Cleaning, inspecting or repairing a JV-KG Series gear flow meter is easily accomplished by following the procedures below.

1. Remove the Sensor (1) from the flow meter body Upper Housing (4). Using a 3mm hex key, loosen the 2 mounting screws inside the sensor.
2. For the JV-30 size and smaller use M6 Bolts (2), loosen them using a 5mm hex key. The JV-60 uses M10 Bolts (2), loosen them using an 8mm hex key. Keep the 2 opposing bolts near the Locating Pins (7) engaged by a few threads to avoid stress on the shafts and the locating pins during housing separation.
Please note the orientation of the Upper and Lower housings with respect to each other so that the meter is reassembled the same way.
3. Holding the Upper Housing (4), gently tap on the top of the 2 opposing bolt heads to separate the Upper Housing (4) from the Lower Housing (9). **Do NOT use chisels or screwdrivers to split and pry apart the housings. This can cause damage to the meter bodies and meter internal parts.**
4. After separation, remove, clean and inspect the gear assemblies (6) and shafts (5). Clean out the o-ring groove, shaft holes and meter cavity.
IMPORTANT: The gear assembly consists of two bearings (6a), the Gear (6b), and a Bearing Spacer (6c). These parts are loosely fitted and can fall out. These parts are matched together and careful attention MUST be made to their orientation and location as they MUST be replaced the exact way they were.
5. After cleaning all parts completely, the Gear Assemblies (6), Shafts (5) and Locating Pins (7) can be reinserted. Check for free and easy rotation of the gears.
6. Replace the O-Ring (8). PTFE o-rings should always be replaced. FKM o-rings can be reused if they are not damaged.
Note: JVx-60KG flow meters use 2 o-rings per meter.
7. During reassembly keep the meter housings as parallel as possible. Make sure the housings are orientated the same way they were prior to disassembly.
8. Replace the Washers (3) and the Bolts (2). Torque the bolts to 15Nm for the 12, 20 and 30 size meters and 30Nm for the 60 size meters. Do not force the meter housings together. Do NOT use a hammer or other such device. Over tightening will not cause damage to the meter, but may fatigue the bolts and/or restrict the operation if internal surfaces are not completely clean.
9. After reassembly, gently blow air through the meter so the gears spin. This should be clearly audible given a moderate background noise level.
10. Clean any debris from the pickup holes before remounting the sensor (1) to the Upper Housing (4). Use a 3mm hex key to tighten the mounting screws in the sensor to mount the sensor on the housing. **Note that there is a correct and incorrect orientation for the sensor to be mounted on the flow meter.** Please see the AW Gear Meters website for documentation if you do not have it. The orientation is noted by the sensor's connector with respect to the outlet port of the flow meter.

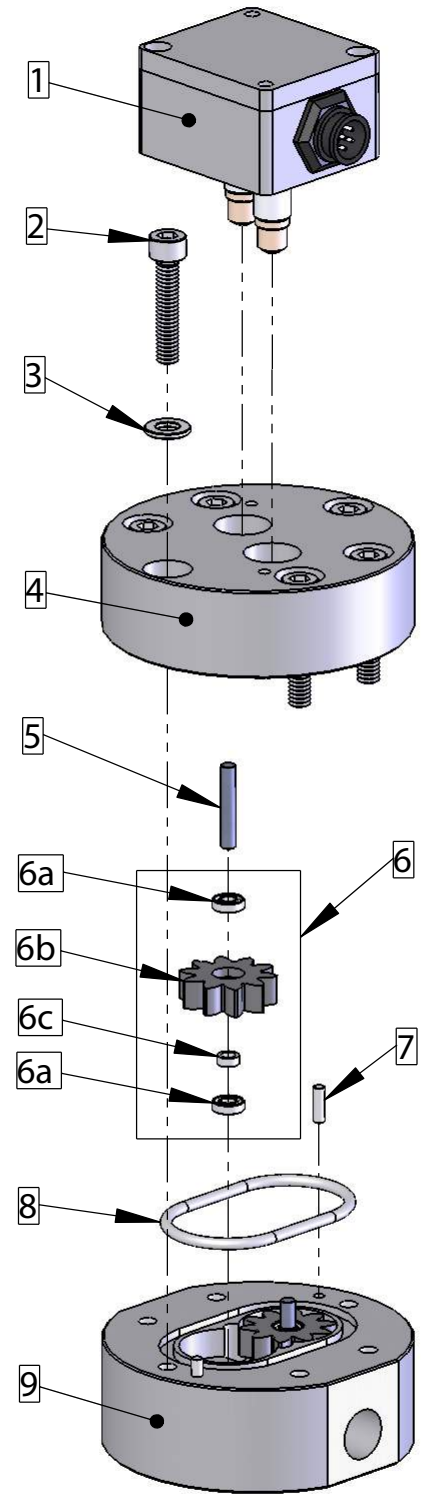

JV-20KG w/ DH-B Shown

CROSS REFERENCE GUIDE FOR JV-XXKG SERIES SPARE PARTS

Part - Qty. per meter [Drawing Ref. #]	JV-12KG	JV-20KG	JV-30KG	JV-60KG
Locating Pin - 2 [7]	AG15030 LP-CG Locating Pin			AG60030 LP-60CG Locating Pin
Shaft - 2 [5]	AG12015 ST-12KG Shaft		AG30055 ST-30KG Shaft	AG60075 ST-60KG Shaft
Gear Assembly - 2 [6]	AG12010 GR-12KG	AG20040 GR-20KG	AG30050 GR-30KG	AG60070 GR-60KG
PTFE O-Ring - 1 [8]	AG12020 COT-12KG	AG15040 COT-15CG		AG60080 - 2 pcs COT-60KG
FKM O-Ring - 1 [8]	AG12025 COV-12KG	AG15045 COV-15CG		AG60085 - 2 pcs COV-60KG
Bolts - 6 [2]	AG15060 - 6 pcs SC-M6x1-30mm - 6 pcs			AG60050 - 12 pcs M10x70mm
Washers - 6 [3]	AG15065 - 6 pcs Washer - M6 Hardened Washer			AG60055 - 12 pcs Washer - M10 Hardened Washer

Table Format:

AG15030	←	AW Part #
LP-CG Locating Pin	←	AW Part Description