



AW-LAKE

PROCESS FLOW MEASUREMENT



▶ VARIABLE AREA & PADDLE WHEEL
FLOW METERS

BASIC INLINE LIQUID VARIABLE AREA FLOW METER

Ideal for monitoring pump performance as well as measuring fluids in hydraulic circuits and cooling systems.



TECHNICAL SPECIFICATIONS

Measuring Accuracy

±2.0% of full scale

Repeatability

±1% of full scale

Flow Measuring Range

0.1-150 GPM (0.5-550 LPM)

Maximum Operating Pressure

Aluminum and brass meters: 3500 PSIG (240 Bar)

Stainless steel meters: 6000 PSIG (410 Bar)

Maximum Operating Temperature

240°F (116°C) Note: for operation to 400°F (204°C), see our High Temperature datasheet.

Standard Calibration Fluids

Oil meters: DTE 25® @ 110°F (43°C), 0.873 sg

Water meters: tap water @ 70°F (21°C), 1.0 sg

Filtration Requirements

74 micron filter or 200 mesh screen minimum

Viscosity

Standard viscosities up to 110 cSt. For viscosities between 110 to 430 cSt contact factory.

DTE 25 is a registered trademark of Exxon Mobil.

BENEFITS

Choice of Materials

Select from aluminum, brass or stainless steel to meet system and liquid requirements.

Unrestricted Mounting

Allows for horizontal, vertical or inverted installation and does not require straight plumbing on inlet or outlet.

Superior Exterior Design

Weather-tight for use outdoors and/or on systems where wash downs are required.

Rugged and Reliable

These meters are constructed with all metal pressure vessels that allow safe and permanent installation.

High Pressure Operation

The magnetically coupled follower design allows operation to 6000 PSIG.

Multiple Ports Available

Standard selection of NPT, SAE and BSPP ports reduces the amount of adapters required for installation.

MATERIALS OF CONSTRUCTION (NON-WETTED COMPONENTS)

	Aluminum	Brass	Stainless Steel
Window Tube	Polycarbonate	Polycarbonate	Polycarbonate
Window Seals	Buna-N® (STD), PTFE	Buna-N® (STD), PTFE	Buna-N® (STD), PTFE

MATERIALS OF CONSTRUCTION (WETTED COMPONENTS)

	Aluminum	Brass	Stainless Steel
Casing & End Ports	Anodized Aluminum	Brass	Stainless Steel
Seals	Buna-N® (STD), EPR, FKM or FFKM	Buna-N® (STD), EPR, FKM or FFKM	FKM with PTFE backup (STD), Buna-N®, EPR or FFKM
Transfer Magnet	PTFE coated Alnico	PTFE coated Alnico	PTFE coated Alnico
All other internal parts	Stainless Steel	Stainless Steel	Stainless Steel

Buna-N is a registered trademark of Chemische Werke Huls.



2440 W. Corporate Preserve Dr. #600, Oak Creek, WI 53154 | www.aw-lake.com

©2016 AW-Lake Company. All rights reserved. Doc ID: BASDS16 REV 10.25

BASIC INLINE LIQUID VARIABLE AREA FLOW METER

Ideal for monitoring pump performance as well as measuring fluids in hydraulic circuits and cooling systems.

PART NUMBER GUIDE

- - -

BASIC

PORT SIZE RANGE

1/4" - 1/2" =

3/4" - 1" =

1-1/4" - 2" =

MATERIAL

Aluminum =

Brass =

Stainless Steel =

MAX. PRESSURE RATING

3500 psig (liquids, aluminum & brass) =

6000 psig (liquids, stainless steel) =

FLUID MEDIA

Oil @ 0.873 specific gravity =

Water @ 1.0 specific gravity =

Note: For special scales consult factory.

End-of-Life Disposal:

At the end of its service life, this product and its associated electronics should **not be discarded with municipal solid waste**. We strongly recommend recycling the unit in accordance with **all applicable local, state, and federal regulations**. Electronic components may qualify as universal waste and should be handled through an appropriate recycling or collection program. Responsible recycling supports our commitment to environmental stewardship under **ISO 14001**.

PORTING/THREAD TYPE

(all female)

1/4" NPTF, dry seal	3 only = <input type="text" value="S"/>
3/8" NPTF, dry seal	3 only = <input type="text" value="A"/>
1/2" NPTF, dry seal	3 only = <input type="text" value="B"/>
3/4" NPTF, dry seal	4 only = <input type="text" value="C"/>
1" NPTF, dry seal	4 only = <input type="text" value="D"/>
#6 SAE, O-ring seal	3 only = <input type="text" value="E"/>
#8 SAE, O-ring seal	3 only = <input type="text" value="F"/>
#10 SAE, O-ring seal	3 only = <input type="text" value="G"/>
#12 SAE, O-ring seal	4 only = <input type="text" value="H"/>
#16 SAE, O-ring seal	4 only = <input type="text" value="J"/>
1-1/4" NPTF, dry seal	5 only = <input type="text" value="K"/>
1-1/2" NPTF, dry seal	5 only = <input type="text" value="L"/>
2" NPTF, dry seal	5 only = <input type="text" value="M"/>
#20 SAE, O-ring seal	5 only = <input type="text" value="N"/>
#24 SAE, O-ring seal	5 only = <input type="text" value="P"/>
#32 SAE, O-ring seal	5 only = <input type="text" value="Q"/>
1/4" BSPP	3 only = <input type="text" value="8"/>
3/8" BSPP	3 only = <input type="text" value="R"/>
1/2" BSPP	3 only = <input type="text" value="T"/>
3/4" BSPP	4 only = <input type="text" value="U"/>
1" BSPP	4 only = <input type="text" value="V"/>
1-1/4" BSPP	5 only = <input type="text" value="W"/>
1-1/2" BSPP	5 only = <input type="text" value="Y"/>
2" BSPP	5 only = <input type="text" value="X"/>

Note: SAE porting not available in Brass. Consult factory for SAE brass meter requirements.

SPECIAL SCALE/CUSTOM PRODUCT

OPTIONAL FLOW DIRECTIONS

Standard Flow, Uni-Directional =

Reverse Flow =

Bi-Directional Flow (For bi-directional flow refer to bi-directional data sheet. Please consult factory for availability and delivery time.)

FLOW RANGES

Liquid	Size	3 only =	3 & 4 =	3 & 4 =	3 & 4 =	3 & 4 =	4 only =	4 & 5 =	4 only =	4 only =	4 & 5 =	5 only =	5 only =	5 only =
0.1-1.0 GPM	0.5-4 LPM	<input type="text" value="0"/> <input type="text" value="1"/>	<input type="text" value="0"/> <input type="text" value="2"/>	<input type="text" value="0"/> <input type="text" value="5"/>	<input type="text" value="1"/> <input type="text" value="0"/>	<input type="text" value="1"/> <input type="text" value="5"/>	<input type="text" value="2"/> <input type="text" value="0"/>	<input type="text" value="2"/> <input type="text" value="5"/>	<input type="text" value="3"/> <input type="text" value="0"/>	<input type="text" value="4"/> <input type="text" value="0"/>	<input type="text" value="5"/> <input type="text" value="0"/>	<input type="text" value="7"/> <input type="text" value="5"/>	<input type="text" value="8"/> <input type="text" value="8"/>	<input type="text" value="9"/> <input type="text" value="9"/>
0.2-2.0 GPM	1-8 LPM													
0.5-5.0 GPM	2-19 LPM													
1-10 GPM	5-37.5 LPM													
1-15 GPM	5-55 LPM													
2-20 GPM	10-75 LPM													
2-25 GPM	10-95 LPM													
4-30 GPM	15-115 LPM													
4-40 GPM	20-150 LPM													
6-50 GPM	20-190 LPM													
6-75 GPM	30-280 LPM													
10-100 GPM	50-375 LPM													
25-150 GPM	100-550 LPM													

MECHANICAL - SIZE CODE

DIM	Series 3	Series 4	Series 5	Series 5 (2" port only)
A	1-7/8" (48mm)	2-3/8" (60 mm)	3-1/2" (90mm)	3-1/2" (90mm)
B	6-9/16" (167mm)	7-5/32" (182mm)	10-1/8" (258mm)	12-5/8" (322mm)



Products may be subject to change without notice - Contact factory for the most up-to-date product information.



2440 W. Corporate Preserve Dr. #600, Oak Creek, WI 53154 | www.aw-lake.com

©2016 AW-Lake Company. All rights reserved. Doc ID: BASDS16 REV 10.25

FLOW RATE TRANSMITTERS

Flow Rate Transmitter is ideal for batching, industrial process control, mobile hydraulic equipment and computer / PLC controlled hydraulic system monitoring application. Available in analog or pulse outputs.



TECHNICAL SPECIFICATIONS

Measuring Accuracy

±2.0% of full scale for oil and water
±2.5% of full scale in center third of measuring range; ±4% in upper & lower thirds for air and gas

Repeatability

±1% of full scale

Flow Measuring Range

0.1-150 GPM (0.5-550 LPM)
2-1300 SCFM (1-600 SLPS)

Standard Calibration Fluids

Oil monitors: DTE 25® @ 110°F (43°C), 0.873 sg

Water monitors: tap water @ 70°F (21°C), 1.0 sg

Air monitors: air @ 70°F (21°C), 1.0 sg and 100 PSIG (6.8 Bar)

Maximum Operating Pressure

Liquids

Aluminum and brass monitors: 3500 PSIG (240 Bar)
Stainless steel: 6000 PSIG (410 Bar)

Air/Gas

Aluminum and brass: 600 PSIG (40 Bar)
Stainless steel: 1000 PSIG (69 Bar)

Maximum Operating Temperature

Media: 185°F (85°C)
Ambient: 185°F (85°C)

Filtration Requirements

74 micron filter or 200 mesh screen minimum

Viscosity

Standard viscosities up to 110 cSt. For viscosities between 110 to 430 cSt contact factory.

BENEFITS

Simple to Install

All transmitters are factory calibrated and ship fully assembled. Simply install the transmitter into your system and apply power. No straight plumbing required at inlet or outlet.

Industry Standard Outputs

Transmitters provide proportional analog or pulse outputs that will drive popular data acquisition devices, meters and analog input cards.

Direct Reading

All transmitters provide a visual indication of flow rate that matches the transmitted output.

Weather-Tight Construction

The rugged cast aluminum enclosure is built to NEMA 4X standard and allows installation outdoors and in environments where liquid tight seals are required.

Rugged and Reliable

Without delicate internal components to break, abrade or corrode, the flow transmitter will provide many years of low-maintenance service.

DTE 25 is a registered trademark of Exxon Mobil.

ELECTRONIC TRANSMITTER PERFORMANCE

Power Requirements

12-24 VDC, Regulated

Load Driving capacity

4-20mA: Load resistance is dependent on power supply voltage.

Use the following equation to calculate maximum load resistance:

Max Loop Load (Ω) = 50 (Power supply volts – 12).

0-5 VDC (regulated): Minimum load resistance 1000 Ω .

1-5 VDC* (regulated): Minimum load resistance 25 K Ω

Square Wave Pulse: Minimum load resistance 1000 Ω

Transmission Distance

4-20mA and 1-5 VDC (regulated) are limited only by wire resistance and power supply voltage.

<200 feet recommended for 0-5 VDC (regulated) and square wave pulse.

Over-Current Protection

Self limiting at 35mA

Resolution

10-bit (0.1%)

Response Time

<100 milliseconds

**The 1-5 VDC output requires an external 249 ohm resistor (not included with transmitter) to be wired at the receiving device.*

FLOW RATE TRANSMITTERS

Flow Rate Transmitter is ideal for batching, industrial process control, mobile hydraulic equipment and computer / PLC controlled hydraulic system monitoring application. Available in analog or pulse outputs.

ENCLOSURE MATERIALS OF CONSTRUCTION (NON-WETTED COMPONENTS)

Enclosure & Cover	Painted Aluminum	Painted Aluminum	Painted Aluminum
Seals	Buna-N®	Buna-N	Buna-N
Window	Pyrex®	Pyrex	Pyrex
Din Connector	Polyamide	Polyamide	Polyamide

Buna-N is a registered trademark of Chemische Werke Huls. Pyrex® is a registered trademark of Corning Incorporated.

FLOW METER MATERIALS OF CONSTRUCTION (WETTED COMPONENTS)

Casing & End Ports	Anodized Aluminum	Brass	Stainless Steel 303
Seals	Buna-N (STD), EPR, FKM or Kalrez®	Buna-N (STD), EPR, FKM or Kalrez	FKM with PTFE backup (STD), Buna-N, EPR or Kalrez
Transfer Magnet	PTFE coated Alnico	PTFE coated Alnico	PTFE coated Alnico
All other internal parts	Stainless Steel	Stainless Steel	Stainless Steel

Kalrez is a registered trademark of DuPont Incorporated.

MECHANICAL - SIZE CODE



DIM	Series 3	Series 4	Series 5	Series 5 (2" port only)
A	6-9/16" (167mm)	7-5/32" (182mm)	10-1/8" (258mm)	12-5/8" (322mm)
B	2-3/16" (56mm)	2-15/16" (75mm)	3-13/16" (97mm)	3-13/16" (97mm)
C	4" (101mm)	4-1/2" (114mm)	5-5/16" (135mm)	5-5/16" (135mm)
D	1-7/8" (47mm)	1-7/8" (47mm)	1-7/8" (47mm)	1-7/8" (47mm)
E	4-7/8" (128mm)	5" (127mm)	6-3/4" (172mm)	6-3/4" (172mm)
F	2-1/4" (57mm)	2-7/8" (73mm)	3-3/4" (95mm)	3-3/4" (95mm)

FLOW RATE TRANSMITTERS

Flow Rate Transmitter is ideal for batching, industrial process control, mobile hydraulic equipment and computer / PLC controlled hydraulic system monitoring application. Available in analog or pulse outputs.

PART NUMBER GUIDE

R [] [] - [] [] [] - [] [] [] [] - [] [] [] []

TRANSMITTER

R

PORTING/THREAD TYPE

(all female)

1/4" NPTF, dry seal	3 only =	S
3/8" NPTF, dry seal	3 only =	A
1/2" NPTF, dry seal	3 only =	B
3/4" NPTF, dry seal	4 only =	C
1" NPTF, dry seal	4 only =	D
#6 SAE, O-ring seal	3 only =	E
#8 SAE, O-ring seal	3 only =	F
#10 SAE, O-ring seal	3 only =	G
#12 SAE, O-ring seal	4 only =	H
#16 SAE, O-ring seal	4 only =	J
1-1/4" NPTF, dry seal	5 only =	K
1-1/2" NPTF, dry seal	5 only =	L
2" NPTF, dry seal	5 only =	M
#20 SAE, O-ring seal	5 only =	N
#24 SAE, O-ring seal	5 only =	P
#32 SAE, O-ring seal	5 only =	Q
1/4" BSPP	3 only =	8
3/8" BSPP	3 only =	R
1/2" BSPP	3 only =	T
3/4" BSPP	4 only =	U
1" BSPP	4 only =	V
1-1/4" BSPP	5 only =	W
1-1/2" BSPP	5 only =	Y
2" BSPP	5 only =	X
Cartridge		Z

SPECIAL SCALE/CUSTOM PRODUCT

OPTIONAL FLOW DIRECTIONS

Standard Flow, Uni-Directional = [] []
 Reverse Flow = [R] [F]

FLOW RANGES

Liquid	Air	Size
0.1-1.0 GPM	2-12 SCFM	3 only = [0] [1]
0.2-2.0 GPM	4-23 SCFM	3 & 4 = [0] [2]
0.5-5.0 GPM	5-50 SCFM	3 & 4 = [0] [5]
1-10 GPM	10-100 SCFM	3 & 4 = [1] [0]
1-15 GPM	25-150 SCFM	3 & 4 = [1] [5]
2-20 GPM	20-215 SCFM	4 only = [2] [0]
2-25 GPM	20-250 SCFM	4 & 5 = [2] [5]
3-30 GPM	30-330 SCFM	4 only = [3] [0]
4-40 GPM	30-400 SCFM	4 only = [4] [0]
5-50 GPM	40-500 SCFM	4 only = [5] [0]
5-50 GPM	30-470 SCFM	5 only = [5] [0]
8-75 GPM	30-750 SCFM	5 only = [7] [5]
10-100 GPM	150-900 SCFM	5 only = [8] [8]
20-150 GPM	150-1300 SCFM	5 only = [9] [9]

PORT SIZE RANGE

1/4" - 1/2" = [3]
 3/4" - 1" = [4]
 1-1/4" - 2" = [5]

MATERIAL

Aluminum = [A]
 Brass = [B]
 Stainless Steel = [S]

MAX. PRESSURE RATING

600 psig (air & gas, aluminum & brass) = [4]
 1000 psig (air & gas, stainless steel) = [5]
 3500 psig (liquids, aluminum & brass) = [6]
 6000 psig (liquids, stainless steel) = [7]

FLUID MEDIA

Air & Gases = [A]
 Oil @ 0.873 specific gravity = [H]
 Water @ 1.0 specific gravity = [W]

Note: For special scales consult the factory.

Note: SAE porting not available in Brass. Consult factory for SAE brass monitor requirements.

End-of-Life Disposal:

At the end of its service life, this product and its associated electronics should **not be discarded with municipal solid waste**. We strongly recommend recycling the unit in accordance with **all applicable local, state, and federal regulations**. Electronic components may qualify as universal waste and should be handled through an appropriate recycling or collection program. Responsible recycling supports our commitment to environmental stewardship under **ISO 14001**.

Products may be subject to change without notice - Contact factory for the most up-to-date product information.



2440 W. Corporate Preserve Dr. #600, Oak Creek, WI 53154 | www.aw-lake.com

©2016 AW-Lake Company. All rights reserved. Doc ID: FLOTRANSDS16 REV 10.25

CLEARVIEW VALUE FLOW METER

ClearView Flow Meter is an economical way to monitor water flows, observe case drain flows and verify pump outputs.



TECHNICAL SPECIFICATIONS

Measuring Accuracy
±2% of full scale

Repeatability
±1% of full scale

Flow Measuring Range
1-30 GPM (5-110 LPM)

Maximum Operating Pressure
325 PSIG (22.4 Bar)

Maximum Operating Temperature
ClearView H2O 200°F (93°C) (water only)
ClearView+ 250°F (121°C)

Standard Calibration Fluids
Oil monitors: DTE 25° @110°F (43°C),
0.873 sg
Water monitors: tap water @70°F (21°C),
1.0 sg

Filtration Requirements
74 micron filter or 200 mesh screen
minimum

BENEFITS

Visual Inspection of Fluid

The transparent body allows for visual inspection of fluid conditions. Diagnose problems at a glance.

Unrestricted Mounting

Allows for horizontal, vertical or inverted installation and does not require straight plumbing on inlet or outlet.

Compact Design

Measures less than 8" long and 2-7/16" diameter with a rigid tube and union nut design.

Multiple Materials and Calibrations Available

With a variety of wetted materials of construction and media calibrations, the meter will be well suited to your process.

Sensing Method Assures Accuracy

The proven variable area piston metering assembly provides accurate, dependable flow rate indication.

MATERIALS OF CONSTRUCTION (WETTED COMPONENTS)

	ClearView H2O	ClearView +
End Ports	Brass, Ryton®	Brass, Ryton®
Seals	Viton	Viton
Spring	Stainless Steel	Stainless Steel
Body	Polycarbonate	Polysulfone
Indicator	Polysulfone	Polysulfone

Ryton is a registered trademark of the Chevron Phillips Chemical Company LLC. Buna-N is a registered trademark of Chemische Werke Huls. DTE is a registered trademark of Exxon Mobil.

MECHANICAL - SIZE CODE

DIM	1/2" Female	3/4" Female	1" Female
A	2-7/16" (62 mm)	2-7/16" (62 mm)	2-7/16" (62 mm)
B - Brass	7-5/32" (182 mm)	7-9/16" (192 mm)	7-9/16" (192 mm)
B - Ryton	7-9/16" (192 mm)	7-9/16" (192 mm)	7-9/16" (192 mm)
Port Type	NPTF, BSPP	NPTF, BSPP	NPTF, BSPP
DIM	1/2" Male	3/4" Male	1" Male
B - Brass	7-21/32" (194 mm)	8-1/64" (204 mm)	8-3/16" (208 mm)
Port Type	NPTF	NPTF	NPTF

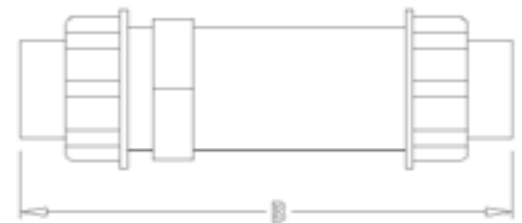

CLEARVIEW VALUE FLOW METER

ClearView Flow Meter is an economical way to monitor water flows, observe case drain flows and verify pump outputs.

PART NUMBER GUIDE

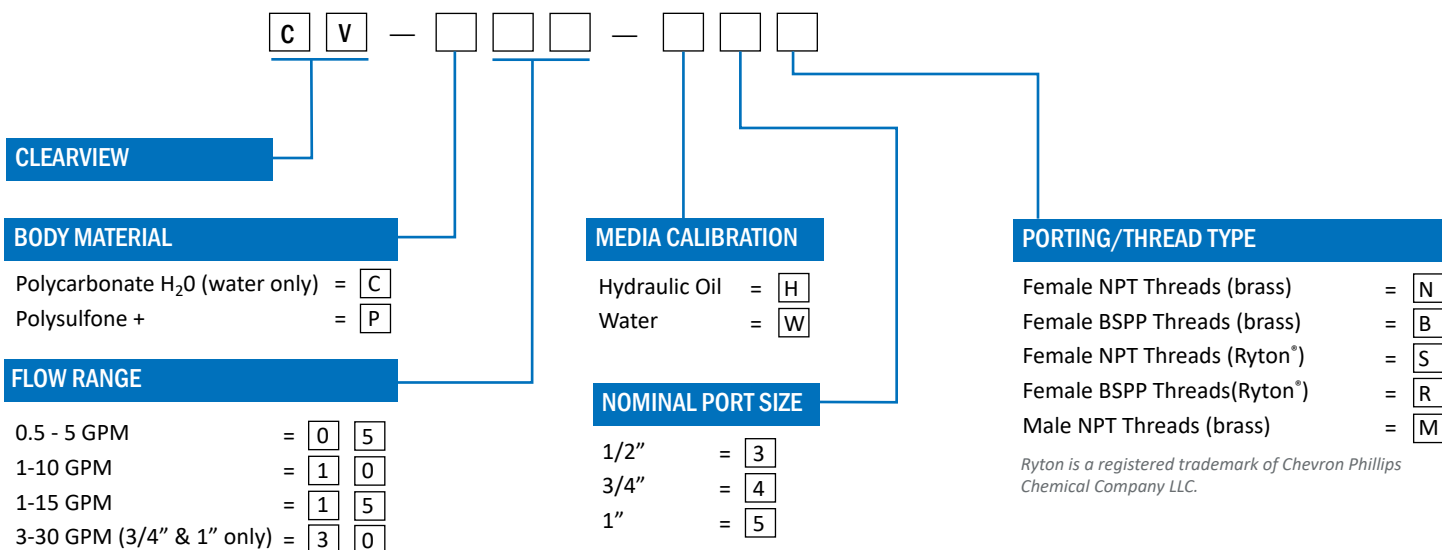

TYPICAL PRESSURE DIFFERENTIALS

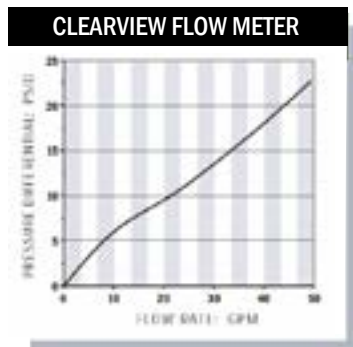

End-of-Life Disposal:

At the end of its service life, this product and its associated electronics should **not be discarded with municipal solid waste**. We strongly recommend recycling the unit in accordance with **all applicable local, state, and federal regulations**. Electronic components may qualify as universal waste and should be handled through an appropriate recycling or collection program. Responsible recycling supports our commitment to environmental stewardship under **ISO 14001**.

Products may be subject to change without notice - Contact factory for the most up-to-date product information.

HIGH TEMPERATURE FLOW METER

High Temperature Flow Meter enables flow monitoring of barrel heating fluids, thermal transfer fluids such as Syltherm® coolant flows, hydraulic circuits and sub-circuits.



TECHNICAL SPECIFICATIONS

Measuring Accuracy

Liquids: ±2.0% of full scale

Air/Gas: ±2.5% of full scale in center third of measuring range; ±4.0% in upper & lower thirds

Repeatability

±1% of full scale

Flow Measuring Range

0.1-150 GPM (0.4-560 LPM)

Maximum Operating Pressure¹

Liquids

Aluminum & brass: 3500 PSIG (240 Bar)
Stainless steel: 6000 PSIG (410 Bar)

Air/Gas

Aluminum & brass: 600 PSIG (40 Bar)
Stainless steel: 1000 PSIG (69 Bar)

Maximum Operating Temperature

400°F (204°C)

Standard Calibration Fluids

Oil meters: DTE 25® @ 110°F (43°C), 0.873 sg

Water meters: water @ 70°F (21°C), 1.0 sg

Air meters: air @ 70°F (21°C), 1.0 sg & 100 PSIG (6.8 bar)

Filtration Requirements

74 micron filter or 200 mesh screen minimum

Viscosity

Standard viscosities up to 110 cSt.
For viscosities between 110 to 430 cSt contact factory.

¹Note: See Temperature/Pressure De-rating Chart on back. DTE 25 is a registered trademark of Exxon Mobil.

BENEFITS

Choice of Materials

Select from aluminum, brass or stainless steel to meet system and media compatibility requirements.

Unrestricted Mounting

Allows for horizontal, vertical or inverted installation and does not require straight plumbing on inlet or outlet.

Multiple Ports Available

Standard selection of NPT, SAE and BSPP ports reduces the amount of adapters required for installation.

Bi-Directional or Reverse Flow Options

High temperature monitors are also available in bidirectional or reverse flow versions.
Contact the factory for more information.

MATERIALS OF CONSTRUCTION (NON-WETTED COMPONENTS)

	Aluminum	Brass	Stainless Steel
Window Tube	Pyrex®	Pyrex®	Pyrex®
Window Seals	PTFE	PTFE	PTFE

Pyrex is a registered trademark of Corning Incorporated.

MATERIALS OF CONSTRUCTION (WETTED COMPONENTS)

	Aluminum	Brass	Stainless Steel
Casing & End Ports	Anodized Aluminum	Brass	Stainless Steel
Seals	FKM w/ PTFE backup	FKM w/ PTFE backup	FKM w/ PTFE backup
Transfer Magnet	PTFE coated Alnico	PTFE coated Alnico	PTFE coated Alnico
All other internal parts	Stainless Steel	Stainless Steel	Stainless Steel

MECHANICAL - SIZE CODE

DIM	Series 3	Series 4	Series 5	Series 5 (2" port only)
A	1-7/8" (48mm)	2-3/8" (60mm)	3-1/2" (90mm)	3-1/2" (90mm)
B	6-9/16" (167 mm)	7-5/32" (182mm)	10-1/8" (258mm)	12-5/8" (322mm)

HIGH TEMPERATURE FLOW METERS

High Temperature Flow Meter enables flow monitoring of barrel heating fluids, thermal transfer fluids such as Syltherm® coolant flows, hydraulic circuits and sub-circuits.

PART NUMBER GUIDE

H - - -

METER STYLE

High Temperature

PORTING/THREAD TYPE

(all female)

1/4" NPTF, dry seal	3 only =	S
3/8" NPTF, dry seal	3 only =	A
1/2" NPTF, dry seal	3 only =	B
3/4" NPTF, dry seal	4 only =	C
1" NPTF, dry seal	4 only =	D
#6 SAE, O-ring seal	3 only =	E
#8 SAE, O-ring seal	3 only =	F
#10 SAE, O-ring seal	3 only =	G
#12 SAE, O-ring seal	4 only =	H
#16 SAE, O-ring seal	4 only =	J
1-1/4" NPTF, dry seal	5 only =	K
1-1/2" NPTF, dry seal	5 only =	L
2" NPTF, dry seal	5 only =	M
#20 SAE, O-ring seal	5 only =	N
#24 SAE, O-ring seal	5 only =	P
#32 SAE, O-ring seal	5 only =	Q
1/4" BSPP	3 only =	8
3/8" BSPP	3 only =	R
1/2" BSPP	3 only =	T
3/4" BSPP	4 only =	U
1" BSPP	4 only =	V
1-1/4" BSPP	5 only =	W
1-1/2" BSPP	5 only =	Y
2" BSPP	5 only =	X

SPECIAL SCALE/CUSTOM PRODUCT

OPTIONAL FLOW DIRECTIONS

Standard Flow, Uni-Directional =

Reverse Flow = R F

Bi-Directional Flow = B I

Note: See bi-directional datasheet for available bi-directional ranges.

FLOW RANGES

Liquid	Air	Size
0.1-1.0 GPM	2-12 SCFM	3 only = 0 1
0.2-2.0 GPM	4-23 SCFM	3 & 4 = 0 2
0.5-5.0 GPM	5-50 SCFM	3 & 4 = 0 5
1-10 GPM	10-100 SCFM	3 & 4 = 1 0
1-15 GPM	25-150 SCFM	3 & 4 = 1 5
2-20 GPM	20-215 SCFM	4 only = 2 0
2-25 GPM	20-250 SCFM	4 & 5 = 2 5
3-30 GPM	30-330 SCFM	4 only = 3 0
4-40 GPM	30-400 SCFM	4 only = 4 0
5-50 GPM	40-500 SCFM	4 only = 5 0
5-50 GPM	30-470 SCFM	5 only = 5 0
8-75 GPM	30-750 SCFM	5 only = 7 5
10-100 GPM	150-900 SCFM	5 only = 8 8
20-150 GPM	150-1300 SCFM	5 only = 9 9

MATERIAL

Aluminum = A

Brass = B

Stainless Steel = S

MAX. PRESSURE RATING

600 psig (air/gas, aluminum & brass) = 4

1000 psig (air/gas, stainless steel) = 5

3500 psig (liquids, aluminum & brass) = 6

6000 psig (liquids, stainless steel) = 7

FLUID MEDIA

Air & Gases = A

Oil & 0.873 specific gravity = H

Water & 1.0 specific gravity = W

Note: For special scales consult the factory.

Note: SAE porting not available in Brass. Consult factory for SAE brass monitor requirements.

TEMPERATURE DE-RATING FOR ALUMINUM & BRASS METERS

AIR & GAS

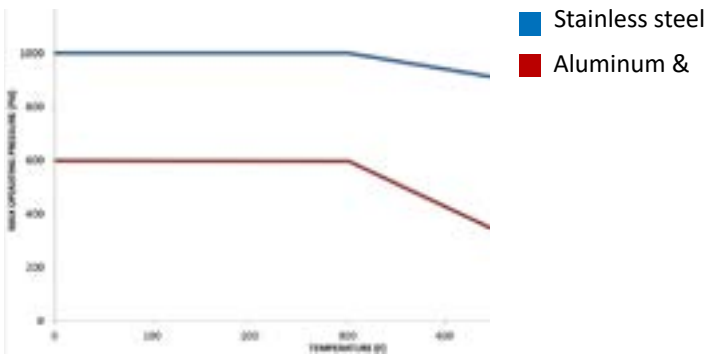

LIQUID

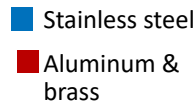

End-of-Life Disposal:

At the end of its service life, this product and its associated electronics should **not be discarded with municipal solid waste**. We strongly recommend recycling the unit in accordance with **all applicable local, state, and federal regulations**. Electronic components may qualify as universal waste and should be handled through an appropriate recycling or collection program. Responsible recycling supports our commitment to environmental stewardship under **ISO 14001**.

Products may be subject to change without notice - Contact factory for the most up-to-date product information.

FLOW RATE ALARMS

Flow Rate Alarm ensures sufficient flows of coolants and lubricants in mobile hydraulic equipment and industrial process control. Field adjustable alarm setting available in single or dual switch.



TECHNICAL SPECIFICATIONS

Measuring Accuracy

±2.0% of full scale for oil and water
±2.5% of full scale in center third of measuring range; ±4% in upper & lower thirds for air and gas

Repeatability

±1% of full scale

Flow Measuring Range

0.1-150 GPM (0.5-550 LPM)
2.0-1300, SCFM (1-600 SLPS)

Maximum Operating Pressure

Liquids:

Aluminum and brass monitors:
3500 PSIG (240 bar)

Stainless steel: 6000 PSIG (410 bar)

Air/Gas:

Aluminum & brass: 600 PSIG (40 bar)

Stainless steel: 1000 PSIG (69 bar)

Maximum Operating Temperature

Media: 185 °F (85°C)

Ambient: 185 °F (85°C)

Standard Calibration Fluids

Oil meters: DTE 25® @ 110°F (43°C), 0.873 sg

Water meters: tap water @ 70°F (21°C), 1.0 sg

Air meters: air @ 70°F (21°C), 1.0 sg and 100 PSIG (6.8 Bar)

Alarm Switch Dead-band

4% of full scale

Alarm Switch Contacts

SPDT (dry contact). 10 amps and 1/4 hp, 125 or 250 VAC. 1/2 amp, 125 VDC (regulated); 1/4 amp, 250 VDC (regulated); 3 amps, 125 VAC "L" (lamp load)

Filtration Requirements

74 micron filter or 200 mesh screen minimum

Viscosity

Standard viscosities up to 110 cSt.
For viscosities between 110 to 430 cSt contact factory.

DTE 25 is a registered trademark of Exxon Mobil.

BENEFITS

Field Adjustable Alarm Setting

Only an allen wrench is required to change the flow alarm setting.

Weather-Tight Construction

Rugged cast aluminum NEMA type 4X enclosure allows installation outdoors and in environments where liquid tight seals are required.

Simple On/Off Logic

Positive alarm points using dry-contact, SPDT switches, reduce the complexity found in standard rotameter OFF/ON/OFF circuits.

Pre-Wired with Cable Disconnect

The standard Hirschmann interconnection provides easy installation and maintenance of the Flow Alarm and the system it is a part of.

Economical Protection

This monitor rapidly pays for itself as it "sounds the alarm" on incorrect pneumatic, lubrication or cooling volumes, protecting expensive equipment and reducing downtime.

ENCLOSURE MATERIALS OF CONSTRUCTION (NON-WETTED COMPONENTS)

Enclosure & Cover	Painted Aluminum	Painted Aluminum	Painted Aluminum
Seals	Buna-N®	Buna-N	Buna-N
Window	Pyrex®	Pyrex	Pyrex
Din Connector	Polyamide	Polyamide	Polyamide

Buna-N is a registered trademark of Chemische Werke Huls. Pyrex® is a registered trademark of Corning Incorporated.

FLOW METER MATERIALS OF CONSTRUCTION (WETTED COMPONENTS)

Casing & End Ports	Anodized Aluminum	Brass	Stainless Steel 303
Seals	Buna-N (STD), EPR, FKM or Kalrez®	Buna-N (STD), EPR, FKM or Kalrez	FKM with PTFE backup (STD), Buna-N, EPR or Kalrez
Transfer Magnet	PTFE coated Alnico	PTFE coated Alnico	PTFE coated Alnico
All other internal parts	Stainless Steel	Stainless Steel	Stainless Steel

Kalrez is a registered trademark of DuPont Incorporated.

FLOW RATE ALARMS

Flow Rate Alarm ensures sufficient flows of coolants and lubricants in mobile hydraulic equipment and industrial process control. Field adjustable alarm setting available in single or dual switch.

PART NUMBER GUIDE

<p>METER STYLE</p> <p>Flow Alarm (1 switch) = <input type="text" value="M"/>*</p> <p>Flow Alarm (2 switches) = <input type="text" value="N"/></p> <p><small>*For units which are to switch in the upper 2/3 of scale, add -A247 to end of M style part number</small></p> <p>PORT SIZE RANGE</p> <p>1/4" - 1/2" = <input type="text" value="3"/></p> <p>3/4" - 1" = <input type="text" value="4"/></p> <p>1-1/4" - 2" = <input type="text" value="5"/></p> <p>MATERIAL</p> <p>Aluminum = <input type="text" value="A"/></p> <p>Brass = <input type="text" value="B"/></p> <p>Stainless Steel = <input type="text" value="S"/></p> <p>MAX. PRESSURE RATING</p> <p>600 psig (air & gas, aluminum & brass) = <input type="text" value="4"/></p> <p>1000 psig (air & gas, stainless steel) = <input type="text" value="5"/></p> <p>3500 psig (liquids, aluminum & brass) = <input type="text" value="6"/></p> <p>6000 psig (liquids, stainless steel) = <input type="text" value="7"/></p> <p>FLUID MEDIA</p> <p>Air & Gases = <input type="text" value="A"/></p> <p>Oil @ 0.873 specific gravity = <input type="text" value="H"/></p> <p>Water @ 1.0 specific gravity = <input type="text" value="W"/></p>	<p>PORTING/THREAD TYPE</p> <p>(all female)</p> <table border="0"> <tr><td>1/4" NPTF, dry seal</td><td>3 only = <input type="text" value="S"/></td></tr> <tr><td>3/8" NPTF, dry seal</td><td>3 only = <input type="text" value="A"/></td></tr> <tr><td>1/2" NPTF, dry seal</td><td>3 only = <input type="text" value="B"/></td></tr> <tr><td>3/4" NPTF, dry seal</td><td>4 only = <input type="text" value="C"/></td></tr> <tr><td>1" NPTF, dry seal</td><td>4 only = <input type="text" value="D"/></td></tr> <tr><td>#6 SAE, O-ring seal</td><td>3 only = <input type="text" value="E"/></td></tr> <tr><td>#8 SAE, O-ring seal</td><td>3 only = <input type="text" value="F"/></td></tr> <tr><td>#10 SAE, O-ring seal</td><td>3 only = <input type="text" value="G"/></td></tr> <tr><td>#12 SAE, O-ring seal</td><td>4 only = <input type="text" value="H"/></td></tr> <tr><td>#16 SAE, O-ring seal</td><td>4 only = <input type="text" value="J"/></td></tr> <tr><td>1-1/4" NPTF, dry seal</td><td>5 only = <input type="text" value="K"/></td></tr> <tr><td>1-1/2" NPTF, dry seal</td><td>5 only = <input type="text" value="L"/></td></tr> <tr><td>2" NPTF, dry seal</td><td>5 only = <input type="text" value="M"/></td></tr> <tr><td>#20 SAE, O-ring seal</td><td>5 only = <input type="text" value="N"/></td></tr> <tr><td>#24 SAE, O-ring seal</td><td>5 only = <input type="text" value="P"/></td></tr> <tr><td>#32 SAE, O-ring seal</td><td>5 only = <input type="text" value="Q"/></td></tr> <tr><td>1/4 BSPP</td><td>3 only = <input type="text" value="8"/></td></tr> <tr><td>3/8" BSPP</td><td>3 only = <input type="text" value="R"/></td></tr> <tr><td>1/2" BSPP</td><td>3 only = <input type="text" value="T"/></td></tr> <tr><td>3/4" BSPP</td><td>4 only = <input type="text" value="U"/></td></tr> <tr><td>1" BSPP</td><td>4 only = <input type="text" value="V"/></td></tr> <tr><td>1-1/4" BSPP</td><td>5 only = <input type="text" value="W"/></td></tr> <tr><td>1-1/2" BSPP</td><td>5 only = <input type="text" value="Y"/></td></tr> <tr><td>2" BSPP</td><td>5 only = <input type="text" value="X"/></td></tr> </table>	1/4" NPTF, dry seal	3 only = <input type="text" value="S"/>	3/8" NPTF, dry seal	3 only = <input type="text" value="A"/>	1/2" NPTF, dry seal	3 only = <input type="text" value="B"/>	3/4" NPTF, dry seal	4 only = <input type="text" value="C"/>	1" NPTF, dry seal	4 only = <input type="text" value="D"/>	#6 SAE, O-ring seal	3 only = <input type="text" value="E"/>	#8 SAE, O-ring seal	3 only = <input type="text" value="F"/>	#10 SAE, O-ring seal	3 only = <input type="text" value="G"/>	#12 SAE, O-ring seal	4 only = <input type="text" value="H"/>	#16 SAE, O-ring seal	4 only = <input type="text" value="J"/>	1-1/4" NPTF, dry seal	5 only = <input type="text" value="K"/>	1-1/2" NPTF, dry seal	5 only = <input type="text" value="L"/>	2" NPTF, dry seal	5 only = <input type="text" value="M"/>	#20 SAE, O-ring seal	5 only = <input type="text" value="N"/>	#24 SAE, O-ring seal	5 only = <input type="text" value="P"/>	#32 SAE, O-ring seal	5 only = <input type="text" value="Q"/>	1/4 BSPP	3 only = <input type="text" value="8"/>	3/8" BSPP	3 only = <input type="text" value="R"/>	1/2" BSPP	3 only = <input type="text" value="T"/>	3/4" BSPP	4 only = <input type="text" value="U"/>	1" BSPP	4 only = <input type="text" value="V"/>	1-1/4" BSPP	5 only = <input type="text" value="W"/>	1-1/2" BSPP	5 only = <input type="text" value="Y"/>	2" BSPP	5 only = <input type="text" value="X"/>	<p>SPECIAL SCALE/CUSTOM PRODUCT</p> <p>OPTIONAL FLOW DIRECTIONS</p> <p>Standard Flow, Uni-Directional = <input type="text" value=""/><input type="text" value=""/></p> <p>Reverse Flow = <input type="text" value="R"/><input type="text" value="F"/></p> <p>FLOW RANGES</p> <table border="0"> <thead> <tr> <th>Liquid</th> <th>Air</th> <th>Size</th> </tr> </thead> <tbody> <tr><td>0.1-1.0 GPM</td><td>2.0-12 SCFM</td><td>3 only = <input type="text" value="0"/><input type="text" value="1"/></td></tr> <tr><td>0.2-2.0 GPM</td><td>4-23 SCFM</td><td>3 & 4 = <input type="text" value="0"/><input type="text" value="2"/></td></tr> <tr><td>0.5-5.0 GPM</td><td>5-50 SCFM</td><td>3 & 4 = <input type="text" value="0"/><input type="text" value="5"/></td></tr> <tr><td>1-10 GPM</td><td>10-100 SCFM</td><td>3 & 4 = <input type="text" value="1"/><input type="text" value="0"/></td></tr> <tr><td>1-15 GPM</td><td>25-150 SCFM</td><td>3 & 4 = <input type="text" value="1"/><input type="text" value="5"/></td></tr> <tr><td>2-20 GPM</td><td>20-215 SCFM</td><td>4 only = <input type="text" value="2"/><input type="text" value="0"/></td></tr> <tr><td>2-25 GPM</td><td>20-250 SCFM</td><td>4 & 5 = <input type="text" value="2"/><input type="text" value="5"/></td></tr> <tr><td>3-30 GPM</td><td>30-330 SCFM</td><td>4 only = <input type="text" value="3"/><input type="text" value="0"/></td></tr> <tr><td>4-40 GPM</td><td>30-400 SCFM</td><td>4 only = <input type="text" value="4"/><input type="text" value="0"/></td></tr> <tr><td>5-50 GPM</td><td>40-500 SCFM</td><td>4 only = <input type="text" value="5"/><input type="text" value="0"/></td></tr> <tr><td>5-50 GPM</td><td>30-470 SCFM</td><td>5 only = <input type="text" value="5"/><input type="text" value="0"/></td></tr> <tr><td>8-75 GPM</td><td>30-750 SCFM</td><td>5 only = <input type="text" value="7"/><input type="text" value="5"/></td></tr> <tr><td>10-100 GPM</td><td>150-900 SCFM</td><td>5 only = <input type="text" value="8"/><input type="text" value="8"/></td></tr> <tr><td>20-150 GPM</td><td>150-1300 SCFM</td><td>5 only = <input type="text" value="9"/><input type="text" value="9"/></td></tr> </tbody> </table>	Liquid	Air	Size	0.1-1.0 GPM	2.0-12 SCFM	3 only = <input type="text" value="0"/> <input type="text" value="1"/>	0.2-2.0 GPM	4-23 SCFM	3 & 4 = <input type="text" value="0"/> <input type="text" value="2"/>	0.5-5.0 GPM	5-50 SCFM	3 & 4 = <input type="text" value="0"/> <input type="text" value="5"/>	1-10 GPM	10-100 SCFM	3 & 4 = <input type="text" value="1"/> <input type="text" value="0"/>	1-15 GPM	25-150 SCFM	3 & 4 = <input type="text" value="1"/> <input type="text" value="5"/>	2-20 GPM	20-215 SCFM	4 only = <input type="text" value="2"/> <input type="text" value="0"/>	2-25 GPM	20-250 SCFM	4 & 5 = <input type="text" value="2"/> <input type="text" value="5"/>	3-30 GPM	30-330 SCFM	4 only = <input type="text" value="3"/> <input type="text" value="0"/>	4-40 GPM	30-400 SCFM	4 only = <input type="text" value="4"/> <input type="text" value="0"/>	5-50 GPM	40-500 SCFM	4 only = <input type="text" value="5"/> <input type="text" value="0"/>	5-50 GPM	30-470 SCFM	5 only = <input type="text" value="5"/> <input type="text" value="0"/>	8-75 GPM	30-750 SCFM	5 only = <input type="text" value="7"/> <input type="text" value="5"/>	10-100 GPM	150-900 SCFM	5 only = <input type="text" value="8"/> <input type="text" value="8"/>	20-150 GPM	150-1300 SCFM	5 only = <input type="text" value="9"/> <input type="text" value="9"/>
1/4" NPTF, dry seal	3 only = <input type="text" value="S"/>																																																																																														
3/8" NPTF, dry seal	3 only = <input type="text" value="A"/>																																																																																														
1/2" NPTF, dry seal	3 only = <input type="text" value="B"/>																																																																																														
3/4" NPTF, dry seal	4 only = <input type="text" value="C"/>																																																																																														
1" NPTF, dry seal	4 only = <input type="text" value="D"/>																																																																																														
#6 SAE, O-ring seal	3 only = <input type="text" value="E"/>																																																																																														
#8 SAE, O-ring seal	3 only = <input type="text" value="F"/>																																																																																														
#10 SAE, O-ring seal	3 only = <input type="text" value="G"/>																																																																																														
#12 SAE, O-ring seal	4 only = <input type="text" value="H"/>																																																																																														
#16 SAE, O-ring seal	4 only = <input type="text" value="J"/>																																																																																														
1-1/4" NPTF, dry seal	5 only = <input type="text" value="K"/>																																																																																														
1-1/2" NPTF, dry seal	5 only = <input type="text" value="L"/>																																																																																														
2" NPTF, dry seal	5 only = <input type="text" value="M"/>																																																																																														
#20 SAE, O-ring seal	5 only = <input type="text" value="N"/>																																																																																														
#24 SAE, O-ring seal	5 only = <input type="text" value="P"/>																																																																																														
#32 SAE, O-ring seal	5 only = <input type="text" value="Q"/>																																																																																														
1/4 BSPP	3 only = <input type="text" value="8"/>																																																																																														
3/8" BSPP	3 only = <input type="text" value="R"/>																																																																																														
1/2" BSPP	3 only = <input type="text" value="T"/>																																																																																														
3/4" BSPP	4 only = <input type="text" value="U"/>																																																																																														
1" BSPP	4 only = <input type="text" value="V"/>																																																																																														
1-1/4" BSPP	5 only = <input type="text" value="W"/>																																																																																														
1-1/2" BSPP	5 only = <input type="text" value="Y"/>																																																																																														
2" BSPP	5 only = <input type="text" value="X"/>																																																																																														
Liquid	Air	Size																																																																																													
0.1-1.0 GPM	2.0-12 SCFM	3 only = <input type="text" value="0"/> <input type="text" value="1"/>																																																																																													
0.2-2.0 GPM	4-23 SCFM	3 & 4 = <input type="text" value="0"/> <input type="text" value="2"/>																																																																																													
0.5-5.0 GPM	5-50 SCFM	3 & 4 = <input type="text" value="0"/> <input type="text" value="5"/>																																																																																													
1-10 GPM	10-100 SCFM	3 & 4 = <input type="text" value="1"/> <input type="text" value="0"/>																																																																																													
1-15 GPM	25-150 SCFM	3 & 4 = <input type="text" value="1"/> <input type="text" value="5"/>																																																																																													
2-20 GPM	20-215 SCFM	4 only = <input type="text" value="2"/> <input type="text" value="0"/>																																																																																													
2-25 GPM	20-250 SCFM	4 & 5 = <input type="text" value="2"/> <input type="text" value="5"/>																																																																																													
3-30 GPM	30-330 SCFM	4 only = <input type="text" value="3"/> <input type="text" value="0"/>																																																																																													
4-40 GPM	30-400 SCFM	4 only = <input type="text" value="4"/> <input type="text" value="0"/>																																																																																													
5-50 GPM	40-500 SCFM	4 only = <input type="text" value="5"/> <input type="text" value="0"/>																																																																																													
5-50 GPM	30-470 SCFM	5 only = <input type="text" value="5"/> <input type="text" value="0"/>																																																																																													
8-75 GPM	30-750 SCFM	5 only = <input type="text" value="7"/> <input type="text" value="5"/>																																																																																													
10-100 GPM	150-900 SCFM	5 only = <input type="text" value="8"/> <input type="text" value="8"/>																																																																																													
20-150 GPM	150-1300 SCFM	5 only = <input type="text" value="9"/> <input type="text" value="9"/>																																																																																													

Note: For special scales consult the factory.

Note: SAE porting not available in Brass.

MECHANICAL - SIZE CODE

DIM	Series 3	Series 4	Series 5	Series 5 (2" port only)
A	6-9/16" (167mm)	7-5/32" (182mm)	10-1/8" (258mm)	12-5/8" (322mm)
B	2-3/16" (56mm)	2-15/16" (75mm)	3-13/16" (97mm)	3-13/16" (97mm)
C	4" (101mm)	4-1/2" (114mm)	5-5/16" (135mm)	5-5/16" (135mm)
D	1-7/8" (47mm)	1-7/8" (47mm)	1-7/8" (47mm)	1-7/8" (47mm)
E	4-7/8" (128mm)	5" (127mm)	6-3/4" (172mm)	6-3/4" (172mm)
F	2-1/4" (57mm)	2-7/8" (73mm)	3-3/4" (95mm)	3-3/4" (95mm)

Products may be subject to change without notice - Contact factory for the most up-to-date product information.

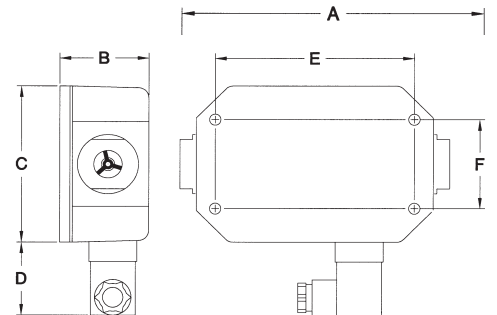

End-of-Life Disposal:

At the end of its service life, this product and its associated electronics should **not be discarded with municipal solid waste**. We strongly recommend recycling the unit in accordance with all applicable local, state, and federal regulations. Electronic components may qualify as universal waste and should be handled through an appropriate recycling or collection program. Responsible recycling supports our commitment to environmental stewardship under ISO 14001.

BI-DIRECTIONAL VARIABLE AREA FLOW METER

Ideal for monitoring pump performance as well as measuring fluids in hydraulic circuits and cooling systems where flow is measured in both directions.



TECHNICAL SPECIFICATIONS

Measuring Accuracy

±4.0% of full scale

Repeatability

±1% of full scale

Flow Measuring Range

0.5-100 GPM (2-350 LPM)

Maximum Operating Pressure

Aluminum and brass meters:
3500 PSIG (240 Bar)

Stainless steel meters:
6000 PSIG (410 Bar)

Maximum Operating Temperature

240°F (116°C) Note: for operation to 400°F (204°C), see our High Temperature datasheet.

Standard Calibration Fluids

Oil meters: DTE 25® @ 110°F (43°C), 0.873 sg

Water meters: tap water @ 70°F (21°C), 1.0 sg

Filtration Requirements

74 micron filter or 200 mesh screen minimum

Viscosity

Viscosities up to 110 cSt

DTE 25 is a registered trademark of Exxon Mobil.

BENEFITS

Choice of Materials

Select from aluminum, brass or stainless steel to meet system and liquid requirements.

Unrestricted Mounting

Allows for horizontal, vertical or inverted installation and does not require straight plumbing on inlet or outlet.

Bi-Directional

Measures bi-directional flow measurement for liquids.

Rugged and Reliable

These meters are constructed with all metal pressure vessels that allow safe & permanent installation.

High Pressure Operation

The magnetically coupled follower design allows operation to 6000 PSIG.

Multiple Ports Available

Standard selection of NPT, SAE and BSPP ports reduces the amount of adapters required for installation.

MATERIALS OF CONSTRUCTION (NON-WETTED COMPONENTS)

	Aluminum	Brass	Stainless Steel
Window Tube	Polycarbonate	Polycarbonate	Polycarbonate
Window Seals	Buna-N® (STD), PTFE	Buna-N® (STD), PTFE	Buna-N® (STD), PTFE

MATERIALS OF CONSTRUCTION (WETTED COMPONENTS)

	Aluminum	Brass	Stainless Steel
Casing & End Ports	Anodized Aluminum	Brass	Stainless Steel
Seals	Buna-N® (STD), EPR, FKM or FFKM	Buna-N® (STD), EPR, FKM or FFKM	FKM with PTFE backup (STD), Buna-N®, EPR or FFKM
Transfer Magnet	PTFE coated Alnico	PTFE coated Alnico	PTFE coated Alnico
All other internal parts	Stainless Steel	Stainless Steel	Stainless Steel

Buna-N is a registered trademark of Chemische Werke Huls.

BI-DIRECTIONAL VARIABLE AREA FLOW METER

Ideal for monitoring pump performance as well as measuring fluids in hydraulic circuits and cooling systems where flow is measured in both directions.

PART NUMBER GUIDE

B — — B I —

BASIC

PORT SIZE RANGE

1/4" - 1/2" = 3

3/4" - 1" = 4

1-1/4" - 2" = 5

MATERIAL

Aluminum = A

Brass = B

Stainless Steel = S

MAX. PRESSURE RATING

3500 psig (liquids, aluminum & brass) = 6

6000 psig (liquids, stainless steel) = 7

FLUID MEDIA

Oil @ 0.873 specific gravity = H

Water @ 1.0 specific gravity = W

Note: For special scales consult the factory.

PORTING/THREAD TYPE

(all female)

1/4" NPTF, dry seal	3 only = S
3/8" NPTF, dry seal	3 only = A
1/2" NPTF, dry seal	3 only = B
3/4" NPTF, dry seal	4 only = C
1" NPTF, dry seal	4 only = D
#6 SAE, O-ring seal	3 only = E
#8 SAE, O-ring seal	3 only = F
#10 SAE, O-ring seal	3 only = G
#12 SAE, O-ring seal	4 only = H
#16 SAE, O-ring seal	4 only = J
1-1/4" NPTF, dry seal	5 only = K
1-1/2" NPTF, dry seal	5 only = L
2" NPTF, dry seal	5 only = M
#20 SAE, O-ring seal	5 only = N
#24 SAE, O-ring seal	5 only = P
#32 SAE, O-ring seal	5 only = Q
1/4" BSPP	3 only = 8
3/8" BSPP	3 only = R
1/2" BSPP	3 only = T
3/4" BSPP	4 only = U
1" BSPP	4 only = V
1-1/4" BSPP	5 only = W
1-1/2" BSPP	5 only = Y
2" BSPP	5 only = X

Note: SAE porting not available in Brass. Consult factory for SAE brass meter requirements.

CUSTOM PRODUCT

OPTIONAL FLOW DIRECTIONS

Bi-Directional Flow = B I

FLOW RANGES

Liquid		Size
0.5-5.0 GPM	2-19 LPM	3 only = 0 5
1-10 GPM	5-37.5 LPM	3 & 4 = 1 0
1-15 GPM	5-55 LPM	3 & 4 = 1 5
2-20 GPM	10-75 LPM	4 only = 2 0
4-30 GPM	15-115 LPM	4 only = 3 0
6-50 GPM	20-190 LPM	5 only = 5 0
6-75 GPM	30-280 LPM	5 only = 7 5
10-100 GPM	50-375 LPM	5 only = 8 8

End-of-Life Disposal:

At the end of its service life, this product and its associated electronics should **not be discarded with municipal solid waste**. We strongly recommend recycling the unit in accordance with **all applicable local, state, and federal regulations**. Electronic components may qualify as universal waste and should be handled through an appropriate recycling or collection program. Responsible recycling supports our commitment to environmental stewardship under **ISO 14001**.

MECHANICAL - SIZE CODE

DIM	Series 3	Series 4	Series 5	Series 5 (2" port only)
A	1-7/8" (48mm)	2-3/8" (60 mm)	3-1/2" (90mm)	3-1/2" (90mm)
B	6-9/16" (167mm)	7-5/32" (182mm)	10-1/8" (258mm)	12-5/8" (322mm)

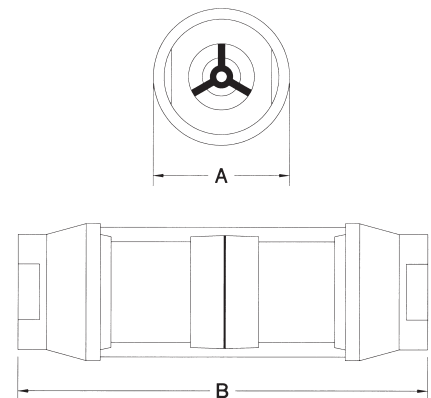

Products may be subject to change without notice - Contact factory for the most up-to-date product information.

PNEUMATIC FLOW METERS

Pneumatic Flow Meters are ideal for monitoring air compressor efficiencies, pneumatic tool air consumption and industrial gas flows.

TECHNICAL SPECIFICATIONS

Measuring Accuracy

±2.5% of full scale in the center third of the measuring range; ±4% in upper and lower thirds

Repeatability

±1% of full scale

Flow Measuring Range

2-1300 SCFM @ 100 PSIG (1-600 SLPS)

Maximum Operating Pressure

Aluminum and brass meters: 600 PSIG (40 Bar)
Stainless steel meters: 1000 PSIG (69 Bar)

Maximum Operating Temperature

240°F (116°C) Note: For operation to 400°F (204°C), see our High Temperature data sheet.

Standard Calibration Fluids

Air @ 70°F (21°C), 1.0 sg and 100 PSIG (6.8 Bar)

Consult factory for scale correction for application conditions & media.

Filtration Requirements

74 micron filter or 200 mesh screen minimum



BENEFITS

Choice of Materials

Select from aluminum, brass or stainless steel to meet system and media compatibility requirements.

Unrestricted Mounting

Allows for horizontal, vertical or inverted installation.

Superior Exterior Design

Weather-tight for use outdoors and/or on systems where wash downs are required.

Rugged and Reliable

These monitors are constructed with all metal pressure vessels, allowing safe, permanent installation in industrial systems.

Multiple Ports Available

Standard selection of NPT, SAE and BSPP ports reduces the amount of adapters required for installation.

MATERIALS OF CONSTRUCTION (NON-WETTED COMPONENTS)

	Aluminum	Brass	Stainless Steel
Window Tube	Polycarbonate	Polycarbonate	Polycarbonate
Window Seals	Buna-N®	Buna-N®	Buna-N®

MATERIALS OF CONSTRUCTION (WETTED COMPONENTS)

	Aluminum	Brass	Stainless Steel
Casing & End Ports	Anodized Aluminum	Brass	Stainless Steel
Seals	Buna-N® (STD), EPR, FKM or FFKM	Buna-N® (STD), EPR, FKM or FFKM	FKM with PTFE backup (STD), Buna-N®, EPR or FFKM
Transfer Magnet	PTFE coated Alnico	PTFE coated Alnico	PTFE coated Alnico
All other internal parts	Stainless Steel	Stainless Steel	Stainless Steel

Buna-N is a registered trademark of Chemische Werke Huls.

PNEUMATIC FLOW METERS

Pneumatic Flow Meters are ideal for monitoring air compressor efficiencies, pneumatic tool air consumption and industrial gas flows.

PART NUMBER GUIDE

G [] [] - [] [] [] - [] [] - [] [] [] []

PNEUMATIC

PORT SIZE RANGE

1/4" - 1/2" = [3]
 3/4" - 1" = [4]
 1-1/4" - 2" = [5]

MATERIAL

Aluminum = [A]
 Brass = [B]
 Stainless Steel = [S]

MAX. PRESSURE RATING

600 psig (air & gas, aluminum & brass) = [4]
 1000 psig (air & gas, stainless steel) = [5]

FLUID MEDIA

Air & Gases = [A]

Note: For special scales consult factory.

PORTING/THREAD TYPE

(all female)

1/4" NPTF, dry seal	3 only = [S]
3/8" NPTF, dry seal	3 only = [A]
1/2" NPTF, dry seal	3 only = [B]
3/4" NPTF, dry seal	4 only = [C]
1" NPTF, dry seal	4 only = [D]
#6 SAE, O-ring seal	3 only = [E]
#8 SAE, O-ring seal	3 only = [F]
#10 SAE, O-ring seal	3 only = [G]
#12 SAE, O-ring seal	4 only = [H]
#16 SAE, O-ring seal	4 only = [J]
1-1/4" NPTF, dry seal	5 only = [K]
1-1/2" NPTF, dry seal	5 only = [L]
2" NPTF, dry seal	5 only = [M]
#20 SAE, O-ring seal	5 only = [N]
#24 SAE, O-ring seal	5 only = [P]
#32 SAE, O-ring seal	5 only = [Q]
1/4 BSPP	3 only = [8]
3/8" BSPP	3 only = [R]
1/2" BSPP	3 only = [T]
3/4" BSPP	4 only = [U]
1" BSPP	4 only = [V]
1-1/4" BSPP	5 only = [W]
1-1/2" BSPP	5 only = [Y]
2" BSPP	5 only = [X]

Note: SAE porting not available in Brass. Consult factory for SAE brass monitor requirements.

SPECIAL SCALE/CUSTOM PRODUCT

FLOW RANGES

Air		Size
2-12 SCFM	1-5.50 SLPS	3 only = [0] [1]
4-23 SCFM	2-10 SLPS	3 & 4 = [0] [2]
5-50 SCFM	3-23 SLPS	3 & 4 = [0] [5]
10-100 SCFM	6-48 SLPS	3 & 4 = [1] [0]
25-150 SCFM	10-70 SLPS	3 & 4 = [1] [5]
20-215 SCFM	10-100 SLPS	4 only = [2] [0]
20-250 SCFM	15-120 SLPS	4 & 5 = [2] [5]
30-330 SCFM	15-150 SLPS	4 only = [3] [0]
30-400 SCFM	15-180 SLPS	4 only = [4] [0]
40-500 SCFM	30-230 SLPS	4 only = [5] [0]
30-470 SCFM	30-210 SLPS	5 only = [5] [0]
30-750 SCFM	25-350 SLPS	5 only = [7] [5]
150-900 SCFM	50-450 SLPS	5 only = [8] [8]
150-1300	100-600 SLPS	5 only = [9] [9]

MECHANICAL - SIZE CODE

DIM	Series 3	Series 4	Series 5	Series 5 (2" port only)
A	1-7/8" (48mm)	2-3/8" (60 mm)	3-1/2" (90mm)	3-1/2" (90mm)
B	6-9/16" (167mm)	7-5/32" (182mm)	10-1/8" (258mm)	12-5/8" (322mm)

Products may be subject to change without notice - Contact factory for the most up-to-date product information.



- ♻️ -

End-of-Life Disposal:

At the end of its service life, this product and its associated electronics should **not be discarded with municipal solid waste**. We strongly recommend recycling the unit in accordance with **all applicable local, state, and federal regulations**. Electronic components may qualify as universal waste and should be handled through an appropriate recycling or collection program. Responsible recycling supports our commitment to environmental stewardship under **ISO 14001**.

PHOSPHATE ESTER FLOW METERS

Phosphate Ester Flow Meter is compatible with aviation lubricants such as Skydrol®, and fire-retardant fluids such as Pydraul®, Fyrquil® and Houghton 900 series. Meters are density corrected to 1.145 sg.



TECHNICAL SPECIFICATIONS

Measuring Accuracy
±2.0% of full scale

Repeatability
±1% of full scale

Flow Measuring Range
0.1-130 GPM (0.5 – 500 LPM)

Maximum Operating Pressure
Aluminum and brass meters: 3500 PSIG (240 Bar)
Stainless steel meters: 6000 PSIG (410 Bar)

Maximum Operating Temperature
240°F (116°C)

Standard Calibration Fluids
Tap water @ 70°F (21°C) 1.0 s.g.
Meters are density corrected to 1.145 sg

Filtration Requirements
74 micron filter or 200 mesh screen minimum

BENEFITS

Choice of Materials

Select from aluminum, brass or stainless steel to meet system and liquid requirements.

Unrestricted Mounting

Allows for horizontal, vertical or inverted installation and does not require straight plumbing on inlet or outlet.

Multi-Use

Factory calibrated for phosphate esters, these versatile meters can be used to verify hydraulic power unit outputs, as well as test machinery and tools for proper fluid flow rates.

Rugged and Reliable

These meters are constructed with all metal pressure vessels that allow safe & permanent installation.

High Pressure Operation

The magnetically coupled follower design allows operation to 6000 PSIG and use with liquids.

Multiple Ports Available

Standard selection of NPT, SAE and BSPP ports reduces the amount of adapters required for installation.

MATERIALS OF CONSTRUCTION (NON-WETTED COMPONENTS)

	Aluminum	Brass	Stainless Steel
Window Tube	Pyrex®	Pyrex®	Pyrex®
Window Seals	PTFE	PTFE	PTFE

Pyrex is a registered trademark of Corning Incorporated.

MATERIALS OF CONSTRUCTION (WETTED COMPONENTS)

	Aluminum	Brass	Stainless Steel
Casing & End Ports	Anodized Aluminum	Brass	Stainless Steel
Seals	ERP with PTFE backup FKM or FFKM optional		
Transfer Magnet	PTFE coated Alnico	PTFE coated Alnico	PTFE coated Alnico
All other internal parts	Stainless Steel	Stainless Steel	Stainless Steel

PHOSPHATE ESTER FLOW METERS

Phosphate Ester Flow Meter is compatible with aviation lubricants such as Skydrol®, and fire-retardant fluids such as Pydraul®, Fyrquil® and Houghton 900 series. Meters are density corrected to 1.145 sg.

PART NUMBER GUIDE

P [] [] - [] [] [] - [] [] [] [] - [] [] [] []

PHOSPHATE ESTER

PORT SIZE RANGE

1/4" - 1/2" =

3/4" - 1" =

1-1/4" - 2" =

MATERIAL

Aluminum =

Brass =

Stainless Steel =

MAX. PRESSURE RATING

3500 psig (liquids, aluminum & brass) =

6000 psig (liquids, stainless steel) =

FLUID MEDIA

Phosphate Ester at 1.145 specific gravity =

PORTING/THREAD TYPE

(all female)

1/4" NPTF, dry seal	3 only	=	<input type="text" value="S"/>
3/8" NPTF, dry seal	3 only	=	<input type="text" value="A"/>
1/2" NPTF, dry seal	3 only	=	<input type="text" value="B"/>
3/4" NPTF, dry seal	4 only	=	<input type="text" value="C"/>
1" NPTF, dry seal	4 only	=	<input type="text" value="D"/>
#6 SAE, O-ring seal	3 only	=	<input type="text" value="E"/>
#8 SAE, O-ring seal	3 only	=	<input type="text" value="F"/>
#10 SAE, O-ring seal	3 only	=	<input type="text" value="G"/>
#12 SAE, O-ring seal	4 only	=	<input type="text" value="H"/>
#16 SAE, O-ring seal	4 only	=	<input type="text" value="J"/>
1-1/4" NPTF, dry seal	5 only	=	<input type="text" value="K"/>
1-1/2" NPTF, dry seal	5 only	=	<input type="text" value="L"/>
2" NPTF, dry seal	5 only	=	<input type="text" value="M"/>
#20 SAE, O-ring seal	5 only	=	<input type="text" value="N"/>
#24 SAE, O-ring seal	5 only	=	<input type="text" value="P"/>
#32 SAE, O-ring seal	5 only	=	<input type="text" value="Q"/>
1/4" BSPP	3 only	=	<input type="text" value="8"/>
3/8" BSPP	3 only	=	<input type="text" value="R"/>
1/2" BSPP	3 only	=	<input type="text" value="T"/>
3/4" BSPP	4 only	=	<input type="text" value="U"/>
1" BSPP	4 only	=	<input type="text" value="V"/>
1-1/4" BSPP	5 only	=	<input type="text" value="W"/>
1-1/2" BSPP	5 only	=	<input type="text" value="Y"/>
2" BSPP	5 only	=	<input type="text" value="X"/>

Note: SAE porting not available in Brass. Consult factory for SAE brass monitor requirements.

SPECIAL SCALE/CUSTOM PRODUCT

OPTIONAL FLOW DIRECTIONS

Standard Flow, Uni-Directional =

Reverse Flow =

FLOW RANGES

Liquid		Size
0.1-.95 GPM	0.5-3.75 LPM	3 only = <input type="text" value="0"/> <input type="text" value="1"/>
0.2-1.8 GPM	1.0-7.0 LPM	3 & 4 = <input type="text" value="0"/> <input type="text" value="2"/>
0.5-4.5 GPM	2.0-17.0 LPM	3 & 4 = <input type="text" value="0"/> <input type="text" value="5"/>
1-9.5 GPM	3.0-35.0 LPM	3 & 4 = <input type="text" value="1"/> <input type="text" value="0"/>
1-14 GPM	4.0-52.0 LPM	3 & 4 = <input type="text" value="1"/> <input type="text" value="5"/>
2-19 GPM	5.0-70.0 LPM	4 only = <input type="text" value="2"/> <input type="text" value="0"/>
2-22 GPM	10.0-85.0 LPM	4 & 5 = <input type="text" value="2"/> <input type="text" value="5"/>
3-28 GPM	10.0-105.0 LPM	4 only = <input type="text" value="3"/> <input type="text" value="0"/>
6-35 GPM	15.0-135.0 LPM	4 only = <input type="text" value="4"/> <input type="text" value="0"/>
6-46 GPM	25.0-175.0 LPM	4 only = <input type="text" value="5"/> <input type="text" value="0"/>
6-69 GPM	20.0-180.0 LPM	5 only = <input type="text" value="7"/> <input type="text" value="5"/>
10-90 GPM	50-350 LPM	5 only = <input type="text" value="8"/> <input type="text" value="8"/>
20-130 GPM	100-500 LPM	5 only = <input type="text" value="9"/> <input type="text" value="9"/>

MECHANICAL - SIZE CODE

DIM	Series 3	Series 4	Series 5	Series 5 (2" port only)
A	1-7/8" (48mm)	2-3/8" (60 mm)	3-1/2" (90mm)	3-1/2" (90mm)
B	6-9/16" (167mm)	7-5/32" (182mm)	10-1/8" (258mm)	12-5/8" (322mm)

Products may be subject to change without notice - Contact factory for the most up-to-date product information.



- & - - B -

End-of-Life Disposal:

At the end of its service life, this product and its associated electronics should **not be discarded with municipal solid waste**. We strongly recommend recycling the unit in accordance with **all applicable local, state, and federal regulations**. Electronic components may qualify as universal waste and should be handled through an appropriate recycling or collection program. Responsible recycling supports our commitment to environmental stewardship under **ISO 14001**.

HYDRAULIC SYSTEM TEST ANALYZER

Hydraulic Test Analyzer is used to diagnose faults in hydraulic circuits, determine horsepower and test for component wear and cylinder leakages. Two options are available: K Series (flow & pressure) and T Series (flow, pressure & temperature).



TECHNICAL SPECIFICATIONS

Measuring Accuracy

Flow: $\pm 2\%$ of full scale
 Pressure: $\pm 2.5\%$ of full scale
 Temperature: $\pm 2.5\%$ of full scale

Repeatability

$\pm 1\%$ of full scale – all measurements

Flow Measuring Range

Flow: 0.1–150 GPM (0.5–550 LPM)
 Temperature: 0–250°F (-20–120°C)

Maximum Operating Pressure

Aluminum meters: 3000 PSIG (200 Bar)
 Stainless steel meters: 5000 PSIG (340 Bar)

Maximum Operating Temperature

240°F (116°C)

Standard Calibration Fluid

Oil meters: DTE 25® @ 110°F (43°C), 0.873 sg

Filtration Requirements

74 micron filter or 200 mesh screen minimum

Viscosity

Standard viscosities up to 110 cSt.

DTE 25 is a registered trademark of Exxon Mobil.

MATERIALS OF CONSTRUCTION

Wetted Components		Non-Wetted Components	
Component	Materials	Component	Materials
Needle Valve	Carbon Steel	Window Tube	Polycarbonate
Casing and End ports	Anodized Aluminum (3000 PSIG) Stainless Steel (5000 PSIG)	Window Tube Seals	Buna-N®
Seals	Buna-N® (STD), FKM, EPR, Neoprene optional	Gauge	Brass and Stainless Steel
Transfer Magnet	PTFE coated Alnico	Gauge Window	Acrylic
All other internal parts	Stainless Steel		

Buna-N is a registered trademark of Chemische Werke Huls.

BENEFITS

A Complete Troubleshooting System

Style K consists of the flow meter, precision needle-type load valve and Glycerin filled pressure gauge. Style T adds a Thermowell protected temperature gauge.

Planned Component Repairs

This system analyzer can be part of a predictive maintenance program, allowing strategized pump, valve, motor and cylinder rebuilding.

Compact and Rugged

The complete hydraulic system test analyzer is small enough to fit in a tool box and built to withstand rigorous industrial use.

Non-Electrical

Without batteries to fail or other electrical power connections to make, this system will provide a lifetime of simple and reliable operation.

Metric and US/Standard Measuring Ranges

These multi-measurement analyzers simultaneously measure flow in GPM and LPM, pressure in PSIG and Bar, and temperature in degrees F and C.

Unrestricted Mounting

Accurate measurements can be taken in any mounting orientation, without the straight plumbing required with other analyzer systems.

Reverse Flow Option Available

Optional built-in reverse bypass mechanism prevents potential damage from mis-installation or backflow.

HYDRAULIC SYSTEM TEST ANALYZER

Hydraulic Test Analyzer is used to diagnose faults in hydraulic circuits, determine horsepower and test for component wear and cylinder leakages. Two options are available: K Series (flow & pressure) and T Series (flow, pressure & temperature).

HYDRAULICS DIAGNOSTICS TOOL KIT APPLICATIONS

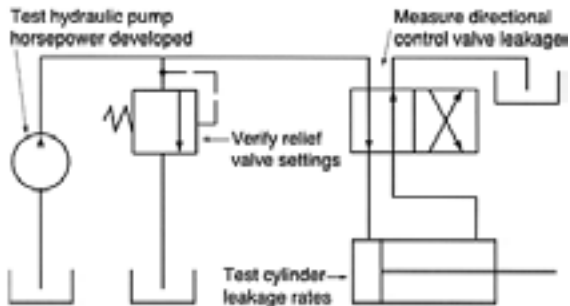

K-STYLE

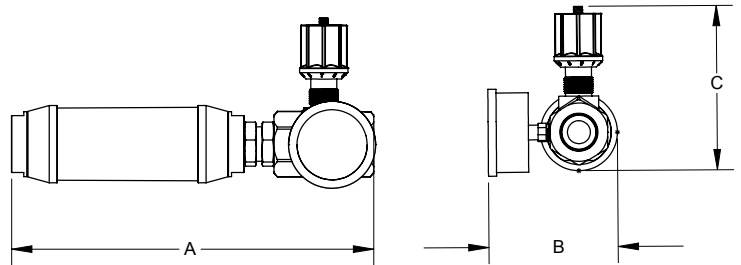

T-STYLE

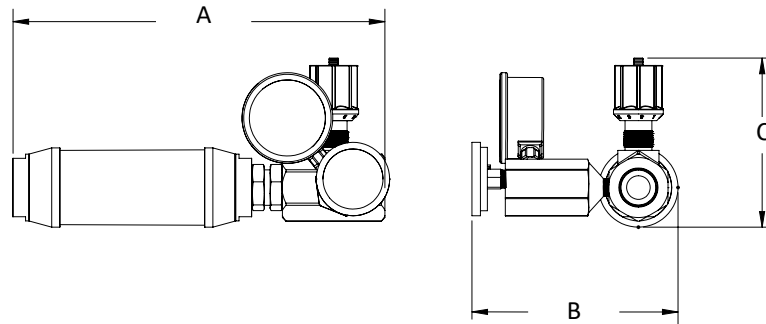
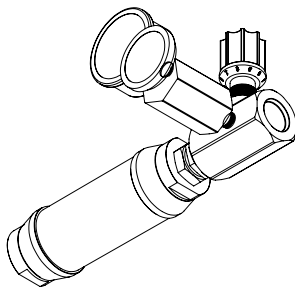

GENERAL DIMENSIONS

(Measurements may vary from meter to meter)

DIM	Series 3	Series 3	Series 4	Series 4	Series 5	Series 5
Port Sizes	3/8" + #6 SAE	1/2" + #8 SAE	3/4" + #12 SAE	1" + #16 SAE	1-1/4" + #20 SAE	1-1/2" + 24 SAE
A	9.75" (248mm)	10.15" (258mm)	11.14" (283mm)	12.7" (323mm)	15.85" (403mm)	15.85" (403mm)
B (K-Style)	3.44" (87mm)	3.54" (90mm)	3.98" (101mm)	4.08" (104mm)	4.84" (123mm)	5.04" (128mm)
B (T-Style)	5.64" (143mm)	5.74" (146mm)	6.18" (157mm)	6.28" (160mm)	7.04" (179mm)	7.24" (184mm)
C	4.11" (104mm)	4.53" (115mm)	5.07" (129mm)	5.88" (149mm)	6.64" (169mm)	6.84" (174mm)

Products may be subject to change without notice - Contact factory for the most up-to-date product information.

HYDRAULIC SYSTEM TEST ANALYZER

Hydraulic Test Analyzer is used to diagnose faults in hydraulic circuits, determine horsepower and test for component wear and cylinder leakages. Two options are available: K Series (flow & pressure) and T Series (flow, pressure & temperature).

PART NUMBER GUIDE

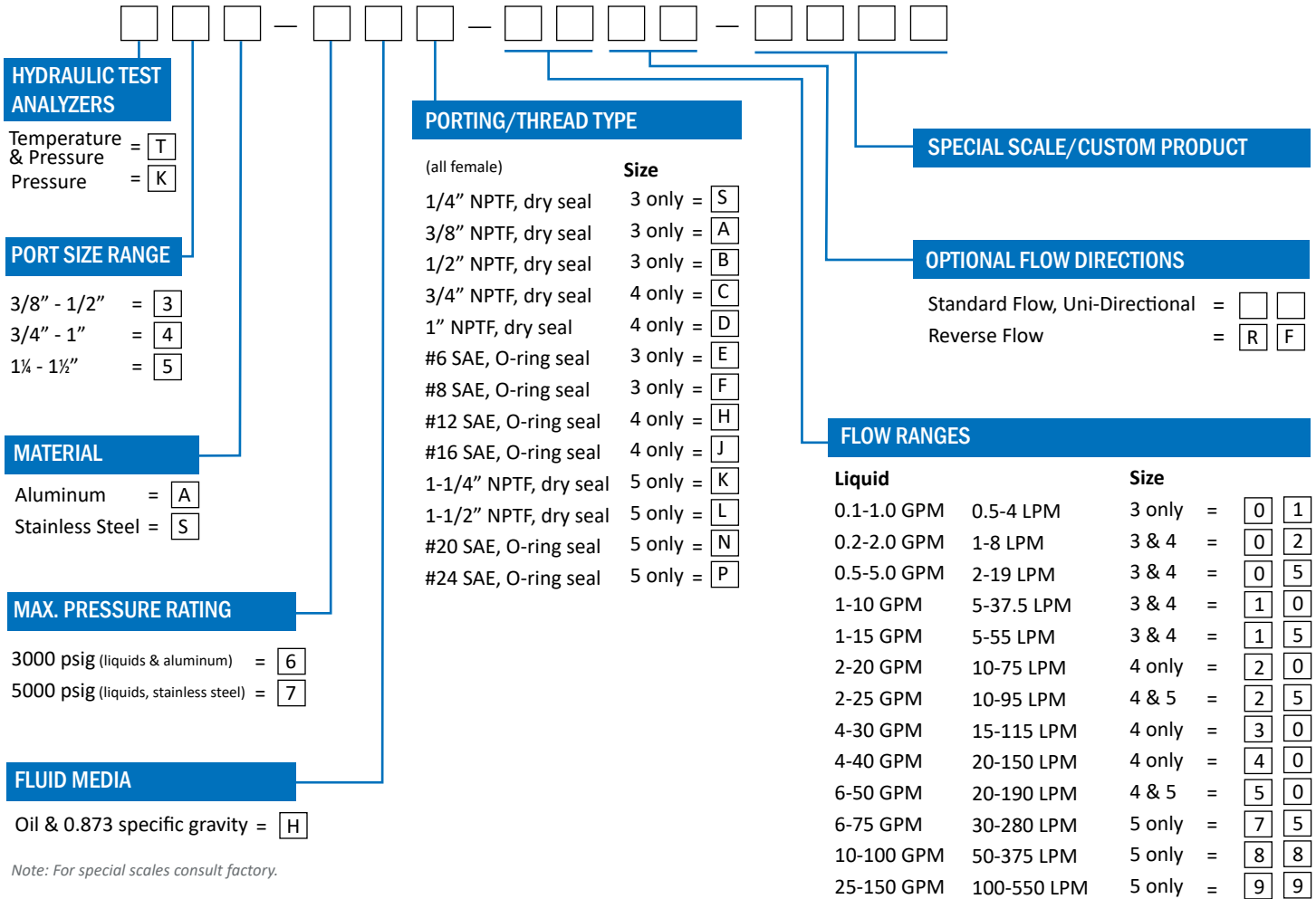

Note: For special scales consult factory.

End-of-Life Disposal:

At the end of its service life, this product and its associated electronics should **not be discarded with municipal solid waste**. We strongly recommend recycling the unit in accordance with **all applicable local, state, and federal regulations**. Electronic components may qualify as universal waste and should be handled through an appropriate recycling or collection program. Responsible recycling supports our commitment to environmental stewardship under **ISO 14001**.

Products may be subject to change without notice - Contact factory for the most up-to-date product information.

WTA SERIES HYDRAULIC ANALYZER

Simple compact design allows for simultaneous measurement of flow, pressure and temperature on Mobile Industrial & Agricultural industries.



BENEFITS

Reversible Flow Indicator

The WTA will allow full flow to pass through in the reverse direction at low pressure but will not measure the reverse flow. This can be useful in situations when the flow and direction are uncertain or a cycle requires reversing, via the raising and lowering of a cylinder.

Easy Connection & No Power Required

The WTA can be connected "In Line" between the pump and valve for convenient machine testing.

Rugged and Reliable

Manufactured in a painted high quality steel case with removable lid. The WTA can withstand the most rigorous of use out in the field.

Loading Valve

A loading valve allows you to simulate pressure on the hydraulic system without the need to operate all the machine functions in the workshop. The multi-stage valve design assures low handle effort and smooth operation over the entire flow and pressure range.

Built-in Thermometer

Heat stressed hydraulic fluids can be a major factor in component failure. The thermometer, calibrated for both °F and °C is a carefully designed and integrated part of a high quality unit, not a bolted-on afterthought.

NOTE: This unit is not designed for permanent installation.

Products may be subject to change without notice - Contact factory for the most up-to-date product information.

FUNCTIONAL SPECIFICATIONS

Measuring Accuracy

Flow: $\pm 4\%$ of full scale
Pressure: $\pm 1.6\%$ of full scale
Temperature: $\pm 5^\circ\text{F}$ ($\pm 2.5^\circ\text{C}$)

Flow Measuring Range

2-32 GPM (10-120 lpm)
2-54 GPM (10-200 lpm)

Maximum Operating Pressure

6000 PSIG (420 Bar)

Standard Calibration Fluids

28cSt Oil

Ambient Temperature

-10 to 50 °C (14 - 122 °F)

Fluid Temperature

68 - 176°F (20 to 80°C) continuous use. Intermittently (< 10 minutes) up to 230°F (110°C).

Fluid Type

Hydraulic oils

Dimensions

310 x 105 x 120 mm (12-1/4" x 4-1/8" x 4-7/8")

Weight

14.5 lbs (6.6kg)

Accessories

A range of burst discs are available - please consult factory.

TECHNICAL SPECIFICATIONS

Model Number	Flow Range		Inlet Fitting	Outlet Fitting
	lpm	gpm		
WTA50	10-200	2-54	1-5/16" - 12UN JIC Male	1-5/16" - 12UN JIC Male

MATERIALS OF CONSTRUCTION

Case	Painted steel - removable lid
RFI body	Aluminum 2011T6
Load valve body	Aluminum 2011T6
Internal components	Stainless Steel, Brass
Seals	Viton

NOTE: This unit is not designed for permanent installation.

End-of-Life Disposal:

At the end of its service life, this product and its associated electronics should **not be discarded with municipal solid waste**. We strongly recommend recycling the unit in accordance with **all applicable local, state, and federal regulations**. Electronic components may qualify as universal waste and should be handled through an appropriate recycling or collection program. Responsible recycling supports our commitment to environmental stewardship under **ISO 14001**.

FLOWSTAT PADDLE WHEEL FLOW SENSOR

Ideal for monitoring various fluids in applications such as chillers/cooling circuits, HVAC, medical equipment, batching and industrial process control applications.

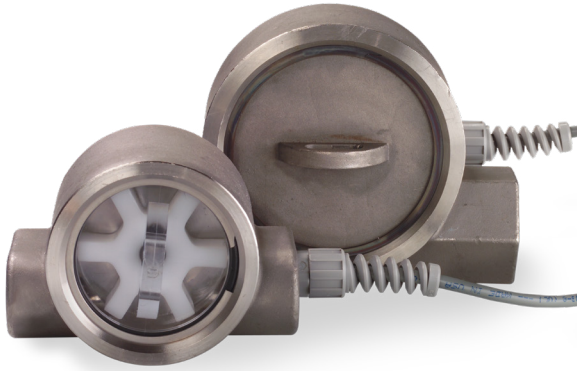

BENEFITS

Choice of Three Port Sizes

Select from 1/2", 3/4" or 1" NPT porting to meet system requirements.

NOTE: Using reduced ID fittings will affect calibrated range.

Encapsulated Circuitry

Withstands the harshest environments.

Several Outputs Available

The standard interface is a 2-wire, 4-20mA current loop. Sensor signal may be transmitted on a low cost wire without degradation. Pulse, relay and 0-5 VDC (regulated) are also available.

Connects Directly to your Flow Monitoring Instruments

Can be connected directly to analog acquisition cards, chart recorders or other monitoring instruments, without external signal conditioning.

Simply Plumb and Apply Power

Comes factory calibrated to your flow range specifications.

Twenty-Four Different Ports Available

Standard selection of NPT, SAE and BSP ports reduces the amount of adapters required for installation.

TECHNICAL SPECIFICATIONS

Measuring Accuracy

±2% of full scale

Repeatability

±0.5% of full scale

Flow Measuring Ranges

- 1/2" porting: 5–15 GPM (20–60 LPM)
- 1/2" porting low flow option: 2.5–4.5 (10–17 LPM)
- 3/4"–1" porting: 15–50 GPM (60–200 LPM)

Turn Down Ratio

10:1

Fluid Temperature Range

20–225°F (-7° to 107°)

Maximum Operating Pressure

Stainless steel cover: 500 PSIG (34 Bar)
Clear polycarbonate cover: 200 PSIG (14 Bar)

Filtration Requirements

150 Micron filter recommended

Standard Calibration Fluid

Water @ 70°F (21°C), 1.0 sg

MATERIALS OF CONSTRUCTION

Wetted Components

Component	Materials
Casing	Stainless Steel 316
Cover	Clear polycarbonate (Optional Stainless Steel 316)
Seal	Buna-N® (other options available)
Impeller	Acetal Copolymer
Bearing	PEEK (Polyetheretherketone)
Shaft	316 Stainless Steel

Non-Wetted Components

Component	Materials
Encapsulant	Epoxy
Strain Relief	Nylon
Lock Ring	Stainless Steel
Wire Insulation	High-Temperature PVC

Buna-N is a registered trademark of Chemische Werke Huls.

FLOWSTAT PADDLE WHEEL FLOW SENSOR

Ideal for monitoring various fluids in applications such as chillers/cooling circuits, HVAC, medical equipment, batching and industrial process control applications.

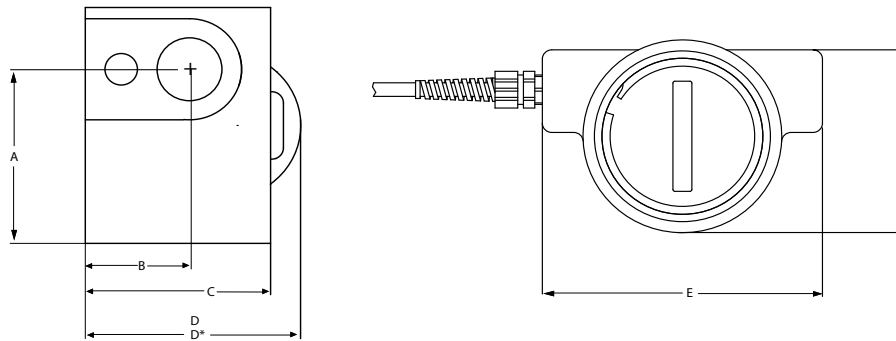

MECHANICAL DIMENSIONS

DIM	1/2" NPTF	3/4" NPTF - 1" NPTF
A	1.94" (49mm)	3.06" (78mm)
B	1.13" (29mm)	1.33" (34mm)
C	2.00" (51mm)	2.46" (62mm)
D	2.45" (62mm)	2.78" (71mm)
D*	2.45" (62mm)	2.88" (73mm)
E	3.70" (94mm)	5.25" (133mm)
F	2.63" (67mm)	3.80" (97mm)

*Dimensions with clear polycarbonate cover installed.

ELECTRONIC SPECIFICATIONS

4-20 mA version		0-5 VDC (regulated) version	
Power Requirements	12-24 VDC, Regulated, Loop powered	Power Requirements	12-24 VDC, Regulated
Load driving capacity	Use the following equation to calculate maximum load resistance: Max Loop Load (Ω) = 50 (Power supply volts - 12).	Maximum Current	25 mA DC, Regulated
Maximum Transmission Distance	Limited only by wire resistance & supply voltage	Minimum Load resistance	1000 Ohms
Response time	2 seconds to 90% (step change)	Maximum Transmission Distance	200 feet recommended
Resolution	Infinite	Resolution	Infinite
Over-current limit	Self limiting at 35 mA	Response time	< 5 seconds to 90% (step change)
Other protection	Reverse polarity		
Relay Output		Pulse Output Version	
Power Requirements	12-24 VDC, Regulated	Power Requirements	12-24 VDC, Regulated
Maximum Transmission Distance	200 feet recommended	Response Time	<100 mS
Switch Contact	Form C, 5A max 120 or 240 VAC	Maximum Current	25 mA DC, Regulated
Set Point Repeatability	1% of full scale	Maximum Transmission Distance	200 feet recommended
		Minimum Load Resistance	1000 Ohms
		Protection	Short circuit & reverse polarity
		K-Factor	1/2" port \approx 200 pulses/gallons 3/4" & 1" ports \approx 60 pulses/gallons

FLOWSTAT PADDLE WHEEL FLOW SENSOR

Ideal for monitoring various fluids in applications such as chillers/cooling circuits, HVAC, medical equipment, batching and industrial process control applications.

PART NUMBER GUIDE

<p>OUTPUT</p> <p>Current = <input type="checkbox"/> C</p> <p>Pulse = <input type="checkbox"/> P</p> <p>Relay = <input type="checkbox"/> R</p> <p>Voltage = <input type="checkbox"/> V</p>	<p>MAX. FLOW RATE: GPM</p> <p>1/2" NPT*: 5 GPM up to 15 GPM Max. flow rates available = <input type="checkbox"/> <input type="checkbox"/></p> <p>3/4" & 1" NPT*: 15 GPM up to 50 GPM Max. = <input type="checkbox"/> <input type="checkbox"/></p> <p><i>*Important: Choose a maximum flow rate. For 1/2" NPT: 5-15 maximum GPM. For 3/4" and 1" NPT: 15-50 maximum GPM. Minimum flow rate will be 10% of maximum flow rate. Example: If your maximum flow rate is 8 GPM, the minimum flow rate would be .8 (8 x .1 = .8) Thus, the correct flow range would be .8-8.0 GPM.</i></p>	<p>OPTIONS</p> <p>Control Cover = <input type="checkbox"/> C</p> <p>Electronic Disconnect = <input type="checkbox"/> D</p> <p>Low Flow Option** = <input type="checkbox"/> L <input type="checkbox"/> F</p> <p><i>** The low flow option will accommodate full-scale flow rates from 2.5 - 4.5 GPM for 1/2" only.</i></p>
<p>ROTOR COVER</p> <p>Clear Polycarbonate to 200 psi = <input type="checkbox"/> C</p> <p>316 Stainless Steel to 500 psi = <input type="checkbox"/> S</p>	<p>COVER SEAL</p> <p>Buna-N (Standard) = <input type="checkbox"/> B</p> <p>EPR (Optional) = <input type="checkbox"/> E</p> <p>FKM (Optional) = <input type="checkbox"/> V</p>	
<p>PORT SIZE RANGE</p> <p>1/2" NPT = <input type="checkbox"/> B</p> <p>3/4" NPT = <input type="checkbox"/> C</p> <p>1" NPT = <input type="checkbox"/> D</p>		

TYPICAL PRESSURE DIFFERENTIALS

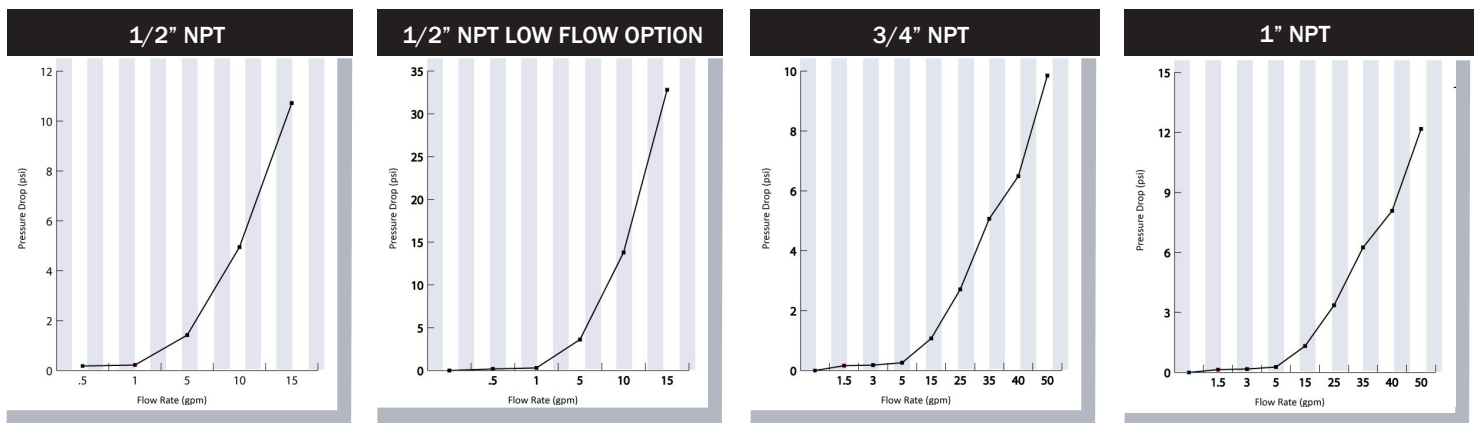

End-of-Life Disposal:

At the end of its service life, this product and its associated electronics should **not be discarded with municipal solid waste**. We strongly recommend recycling the unit in accordance with **all applicable local, state, and federal regulations**. Electronic components may qualify as universal waste and should be handled through an appropriate recycling or collection program. Responsible recycling supports our commitment to environmental stewardship under **ISO 14001**.

Products may be subject to change without notice - Contact factory for the most up-to-date product information.

FLOWSTAT ES TURBINE FLOW SENSOR

Ideal for monitoring various fluids in applications such as chillers/cooling circuits, HVAC, batching and industrial process control applications.



TECHNICAL SPECIFICATIONS

Measuring Accuracy
2% of full-scale

Repeatability
±0.5% of full-scale

Flow Measuring Range
5-15 GPM (20-60 LPM)
With optional low-flow adapter:
2.5-4.5 GPM (10-17 LPM)

Turn Down Ratio
10:1

Maximum Operating Pressure
150 PSIG

Maximum Operating Temperature
20-150°F

Standard Calibration Fluid
Tap water @ 70°F Temperature
(21°C), 1.0 sg

Filtration Requirement
150 Micron Filter recommended

BENEFITS

Value Pricing

Low cost operation combined with low cost maintenance, equals better bottom line savings for your operation.

Encapsulated Circuitry

Withstands the harshest environments.

Several Outputs Available

The standard interface is a 2-wire, 4-20mA current loop. Sensor signal may be transmitted on a low cost wire without degradation. Pulse, relay and 0-5 VDC (regulated) are also available.

Connects Directly to your Flow Monitoring Instruments

Can be connected directly to analog acquisition cards, chart recorders or other monitoring instruments, without external signal conditioning.

Simply Plumb and Apply Power

Comes factory calibrated to your flow range specifications.

MATERIALS OF CONSTRUCTION

Wetted Components		Non-Wetted Components	
Component	Materials	Component	Materials
Casing	Glass-Filled Polypropylene	Encapsulant	Epoxy
Cover	Clear Polycarbonate	Strain Relief	Nylon
Seal	Buna-N® (Other options available)	Lock Ring	Glass-Filled Polypropylene
Impeller	Acetal Copolymer	Wire Insulation	High-Temperature PVC
Bearing	PEEK (Polyetheretherketone)		
Shaft	Stainless Steel		

Buna-N is a registered trademark of Chemische Werke Huls.

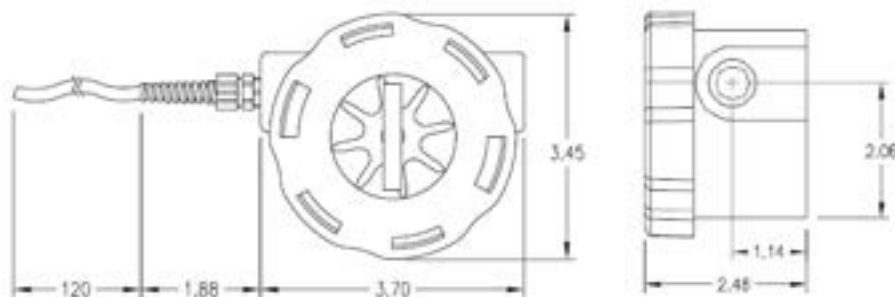

Measurements shown in inches.

FLOWSTAT ES TURBINE FLOW SENSOR

Ideal for monitoring various fluids in applications such as chillers/cooling circuits, HVAC, batching and industrial process control applications.

PART NUMBER GUIDE

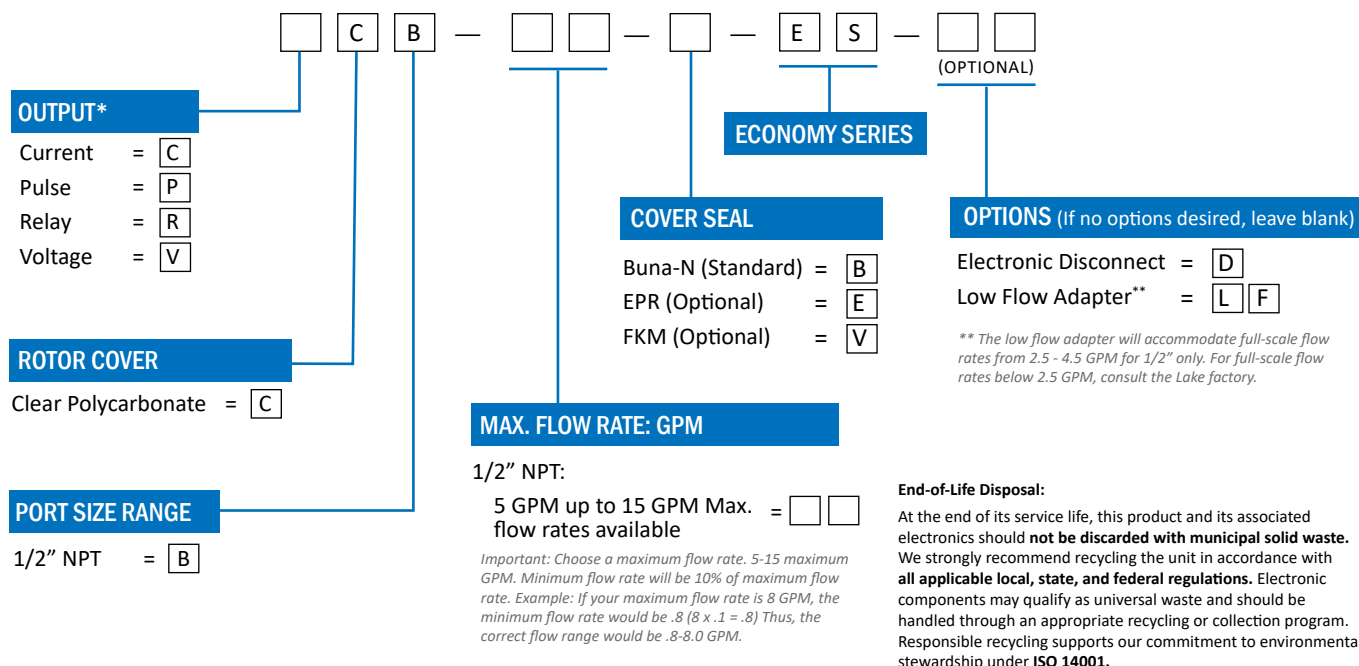

ELECTRONIC SPECIFICATIONS

4-20 mA version	
Power Requirements	12-24 VDC, Regulated, Loop powered
Load driving capacity	Use the following equation to calculate maximum load resistance: Max Loop Load (Ω) = 50 (Power supply volts - 12).
Maximum Transmission Distance	Limited only by wire resistance & supply voltage
Response time	2 seconds to 90% (step change)
Resolution	Infinite
Over-current limit	Self limiting at 35 mA
Other protection	Reverse polarity

0-5 VDC (regulated) version	
Power Requirements	12-24 VDC, Regulated
Maximum Current	25 mA DC, Regulated
Minimum Load resistance	1000 Ohms
Maximum Transmission Distance	200 feet recommended
Resolution	Infinite
Response time	< 5 seconds to 90% (step change)

Relay Output	
Power Requirements	12-24 VDC, Regulated
Maximum Transmission Distance	200 feet recommended
Switch Contact	Form C, 5A max 120 or 240 VAC
Set Point Repeatability	1% of full scale

Pulse Output Version	
Power Requirements	12-24 VDC, Regulated
Response Time	<100 mS
Maximum Current	25 mA DC, Regulated
Maximum Transmission Distance	200 feet recommended
Minimum Load Resistance	1000 Ohms
Protection	Short circuit & reverse polarity

Products may be subject to change without notice - Contact factory for the most up-to-date product information.