



SRZ-10 Helical Flow Meter Maintenance Guide

Disassembly Procedure - Refer to the attached drawing.

Never pry any housing components apart with a chisel or screwdriver. There are delicate carbide shafts inside this unit - to avoid damaging these parts lay the unit horizontally on a flat table or bench and follow the procedures below.

First remove the sensor by releasing the locknut and removing the sensor from the flowmeter housing. Next relax the five hex head bolts (14) at the sensor end (12) with a 5mm Allen hex key. Remove three of the five bolts but keep two opposing bolts engaged by a few threads. With the flowmeter laying on its side on a table, hold the upper housing at the sensor end (12) and gently tap on the two bolts alternately with a hammer until the housing parts (1,3,6) and (9,12) separate. Remove the last two bolts and ease the two flowmeter sections fully apart. **NOTE: Carefully slide the upper housing (9,12) straight off until it is completely clear of the gears (9,10) so as not to break the gear shafts.** Do not attempt to separate housing parts (9) and (12). With the housing separated, remove the small helical gear (9) by turning the gear straight out of the shaft hole. Check that the ball bearing (4) do not fall out. Next remove the five hex head bolts (13) at the inlet end (1) with a 5mm Allen hex key and remove the inlet plate (1). Replace two bolts into the housing (3) in opposite holes. While holding the housing (3), gently tap on the two bolts alternately with a hammer until the housing parts (3) and (6) separate. Check that the ball bearings do not fall out.

Reassembly Procedure - Refer to the attached drawing.

Check the condition of the 3 o-rings (2, 5 & 5), replace them if any deterioration is noticed. Also clean the o-ring groove and the shaft holes holding the ball bearings. Set housing part (6) down with the inlet side pointing up. Check that the o-rings are seated snugly in housing (3) and place it on housing (6) lining up the locator pins. Place the inlet (1) onto housing (3) and screw the housings on hand tight, alternating turns on the bolts so as not to wedge the housing. Make sure the index marks on the housing parts line up. Check that the other o-ring (5) is also fitted snugly in its groove. Next set housing parts (9,12) down on a table. Insert the small helical gear (9) into the sleeve bearing next to the large helical gear, making sure the two helical gears mesh with each other. Turning the gears will help. Next, lay the housings sideways on a table, match the holes in housing (6) with the gears and **carefully** slide the housing (6) over the helical gears. **Make sure to slide the housing on straight without any twisting to avoid stress on the shafts.** Insert two opposing bolts (1) and alternately tighten each down until the two housing parts are together. Insert and tighten down the remaining four bolts with the 5mm Allen hex key. If the parts are reassembled correctly, a snug hand-tight torque will provide a sufficient seal. Reassembly should not require use of a vise.

FOOTNOTE: The use of thread seal tape or pipe dope on the fluid fittings should be avoided as pieces may enter the meter. It is not recommended that the meter be operated or flushed with water. Should this occur, residual water should be removed with alcohol and the internals oiled. If the device is to remain inoperative for any extended period it is recommended that the internals be oiled.

SRZ-10 HELICAL FLOWMETER

REV	DESCRIPTION	DATE	APPR. BY
A	INITIAL RELEASE	03-25-96	C.H.
B	REVISED COMPANY LOGO	12-8-11	JP

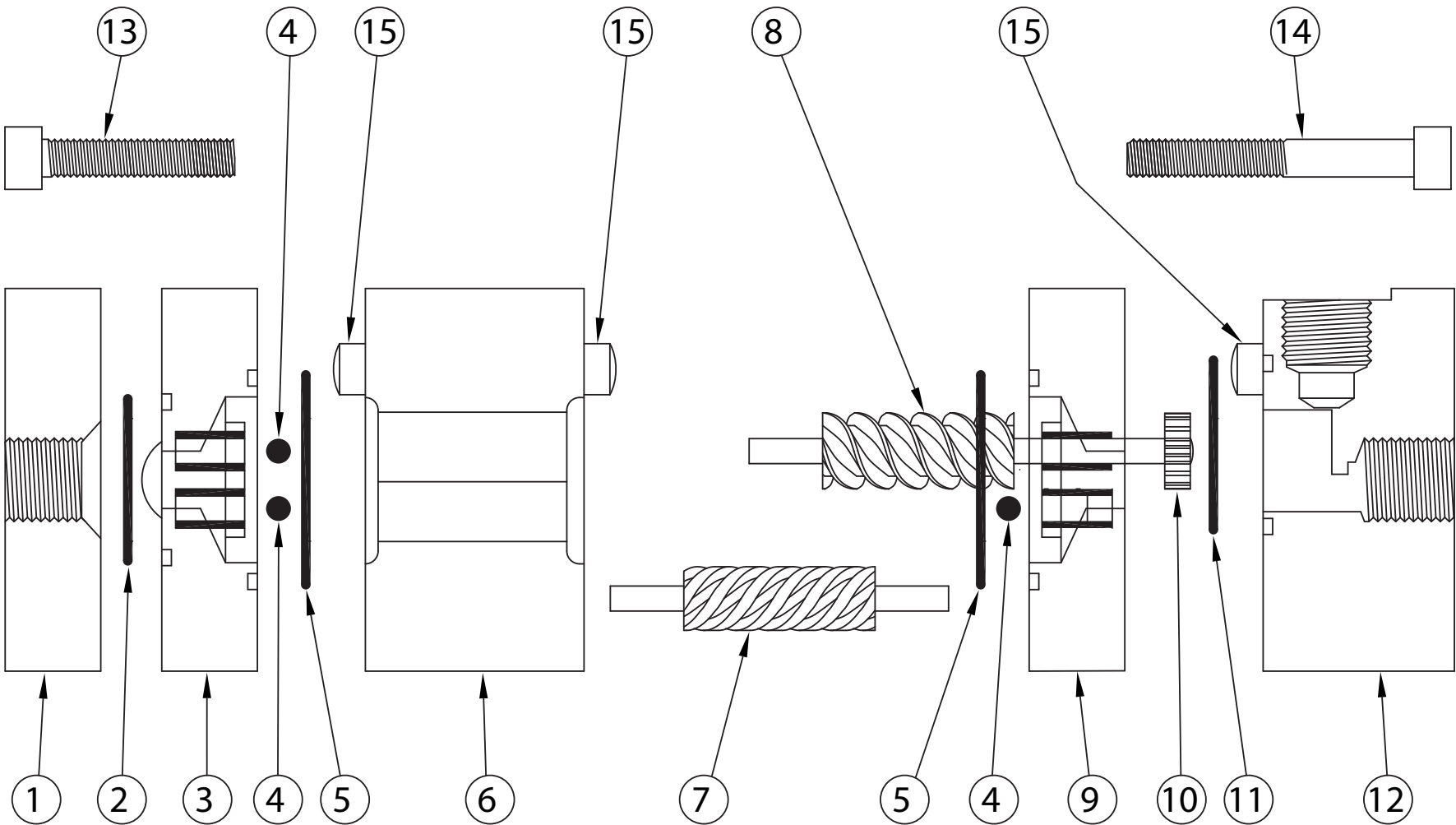

THIS PRINT, INCLUDING THE INFORMATION CONTAINED IN IT, IS THE PROPERTY OF AW-LAKE COMPANY. IT IS CONSIDERED PROPRIETARY IN NATURE AND MAY NOT BE USED OR DISCLOSED OUTSIDE OF AW-LAKE COMPANY EXCEPT UNDER PRIOR WRITTEN AGREEMENT. ANY MODIFICATIONS MADE TO OR COMMENTS WRITTEN ON THIS DRAWING BY UNAUTHORIZED PERSONNEL WILL VOID THIS DRAWING. THIS IS NOT A MANUFACTURING DRAWING UNLESS INDICATED AS SUCH. ANY DIMENSIONS ARE SUBJECT TO CHANGE WITHOUT NOTICE.

AW-LAKE
COMPANY

2440 W. Corporate Preserve Dr. #600
Oak Creek, WI 53154
Phone: 414.574.4300
Fax: 414.574.4301

TITLE: SRZ-10	
DRAWING NUMBER: SRZ1901B	
DRAWN BY: GUS SKIAKER	
DATE: 03-25-96	CHECKED BY: G.S.
PAGE 1 OF 1	SCALE: NONE