

# HM-AC SERIES - HIGH PRESSURE TURBINE FLOW METER

Ideal when measuring the flow of fluids under high pressures, such as in hydraulic testing. It is also ideal for chemical injection systems.



## COMMON APPLICATIONS:

- Dosing & Filling Systems
- 2-Component Mixing Systems
- Process Monitoring
- Water & DI Water
- Inhibitors
- Emulsions
- Fuels, Gasoline, Kerosene
- Methanol

## TECHNICAL SPECIFICATIONS

**Measuring Accuracy**  
± 1.0% of reading or better

**Repeatability**  
± 0.05%

**Flow Measuring Range**  
.08 to 32 GPM (gal/min)

**Turn Down Ratio**  
10:1 (Extended on request)

**Maximum Operating Pressure**  
Working pressure up to 20,000 psi

**Maximum Operating Temperature**  
Depends on sensor used

**Calibration**  
Default is water (1cst), custom calibrations available for added cost

**Filtration Requirement**  
300 microns

**Process Connections**  
Medium pressure AutoClave

## BENEFITS

### Industry Standard

Standard end connections are AutoClave®, (also available in Grayloc® and Techlok®.)

### High Pressure Suitable

The HM Series of turbine flow meters can handle low viscosity fluids flowing under extremely high pressures, such as hydraulic and fuel systems and offshore chemical injection systems.

### Hazardous Area Approved Sensors

A complete line of hazardous area approved sensors and displays are available for the HM Series meters.

### Durable & Cost-Effective

This meter's rugged stainless steel construction provides a durable and economic flow metering solution to sanitary environments.

### Explosion Proof (EX) Options Available

## MATERIALS OF CONSTRUCTION

<b>Body</b>	1.3980 Stainless Steel
<b>Rotor Support</b>	316 Ti Stainless Steel
<b>Rotor</b>	329 Stainless Steel
<b>Bearings/Shaft</b>	Tungsten Carbide

# HM-AC SERIES - HIGH PRESSURE TURBINE FLOW METER

Ideal when measuring the flow of fluids under high pressures, such as in hydraulic testing. It is also ideal for chemical injection systems.

## METER SPECIFICATIONS

Part Number	Range (gal/min)	Medium Pressure AutoClave	K-Factor (Pulses/ gal)	Max. Frequency (0-max. Hz)	Pressure Rating (psi)	Weight (lbs)
HM 003/AC	0.08 to 0.4	9/16"	123,000	1,100	20,000*	4.2
HM 004/AC	0.13 to 1.05	9/16"	94,600	1,700	20,000*	4.4
HM 005/AC	0.2 to 1.6	3/4"	67,400	1,750	20,000*	4.8
HM 006/AC	0.3 to 2.6	3/4"	45,400	2,100	20,000*	4.8
HM 007/AC	0.5 to 5	1"	19,000	1,650	20,000*	5.1
HM 009/AC	0.9 to 9	1"	19,000	2,750	20,000*	5.3
HM 011/AC	1.6 to 16	1"	11,200	3,000	20,000*	5.3
HM 013/AC	2.25 to 22.5	1-1/2"	3,500	1,300	15,000	12.1
HM 017/AC	3.2 to 32	1-1/2"	1,440	840	15,000	12.1

\*Pressure rating drops to 15,000 psi if used with RT-30EX or HUB-40EX sensors.

## RECOMMENDED SENSORS\*

Model	Sensor Type	Temp (°F)
<b>EX Meters</b>		
RT-30EX	Hazardous area rated local flow rate transmitter	-6 to 140
HUB-40EX	Hazardous area rated sensor	-40 to 140
<b>Non EX Meters</b>		
RT-30SD	Local flow rate transmitter	-40 to 140
VTE 02	Pulse output sensor	-40 to 248
VTE 02-EX	Intrinsic safe pulse output sensor	-40 to 185

\*For additional sensors such as extended temperature range, contact factory.

## METER DIMENSIONS

Part Number	A	B	D
HM 003/AC	3.54"	13/16"	1.97"
HM 004/AC	3.54"	13/16"	1.97"
HM 005/AC	4.13"	3/4"	1.97"
HM 006/AC	4.13"	3/4"	1.97"
HM 007/AC	5.31"	1-3/8"	1.97"
HM 009/AC	5.31"	1-3/8"	1.97"
HM 011/AC	5.51"	1-3/8"	1.97"
HM 013/AC	6.89"	1-7/8"	2.76"
HM 017/AC	7.01"	1-7/8"	2.76"

## ORDERING

Contact factory for Part Number Configuration

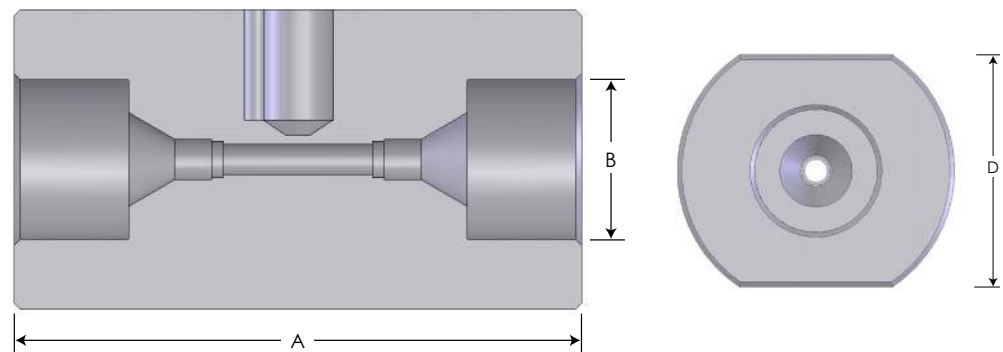

Products may be subject to change without notice - Contact factory for the most up-to-date product information.