

FLOWSTAT TURBINE FLOW SENSOR

Ideal for monitoring various fluids in applications such as chillers/cooling circuits, HVAC, medical equipment, batching and industrial process control applications.



BENEFITS

Choice of Three Port Sizes

Select from 1/2", 3/4" or 1" NPT porting to meet system requirements.

NOTE: Using reduced ID fittings will affect calibrated range.

Encapsulated Circuitry

Withstands the harshest environments.

Several Outputs Available

The standard interface is a 2-wire, 4-20mA current loop. Sensor signal may be transmitted on a low cost wire without degradation. Pulse, relay and 0-5 VDC (regulated) are also available.

Connects Directly to your Flow Monitoring Instruments

Can be connected directly to analog acquisition cards, chart recorders or other monitoring instruments, without external signal conditioning.

Simply Plumb and Apply Power

Comes factory calibrated to your flow range specifications.

Twenty-Four Different Ports Available

Standard selection of NPT, SAE and BSP ports reduces the amount of adapters required for installation.

Low Cost Accuracy

Mid-scale measuring accuracy within $\pm 2.5\%$. Full-scale accuracy within $\pm 4\%$.

TECHNICAL SPECIFICATIONS

Measuring Accuracy

$\pm 2\%$ of full scale

Repeatability

$\pm 0.5\%$ of full scale

Flow Measuring Range

1/2" porting: 0.5-15 GPM (2-60 LPM)

1/2" porting low flow option: 0.25-4.5 (1-17 LPM)

3/4" - 1" porting: 1.5-50 GPM (60-200 LPM)

Turn Down Ratio

10:1

Fluid Temperature Range

20-225°F (-7° to 107°)

Maximum Operating Pressure

Stainless steel cover: 500 PSIG (34 Bar)

Clear polycarbonate cover: 200 PSIG (14 Bar)

Filtration Requirements

150 Micron filter recommended

Standard Calibration Fluid

Water @ 70°F Temperature (21°C), 1.0 sg

MATERIALS OF CONSTRUCTION

Wetted Components

Component	Materials
Casing	Stainless Steel 316
Cover	Clear polycarbonate (Optional Stainless Steel 316)
Seal	Buna-N® (other options available)
Impeller	Acetal Copolymer
Bearing	PEEK (Polyetheretherketone)
Shaft	316 Stainless Steel

Non-Wetted Components

Component	Materials
Encapsulant	Epoxy
Strain Relief	Nylon
Lock Ring	Stainless Steel
Wire Insulation	High-Temperature PVC

Buna-N is a registered trademark of Chemische Werke Huls.

FLOWSTAT TURBINE FLOW SENSOR

Ideal for monitoring various fluids in applications such as chillers/cooling circuits, HVAC, medical equipment, batching and industrial process control applications.

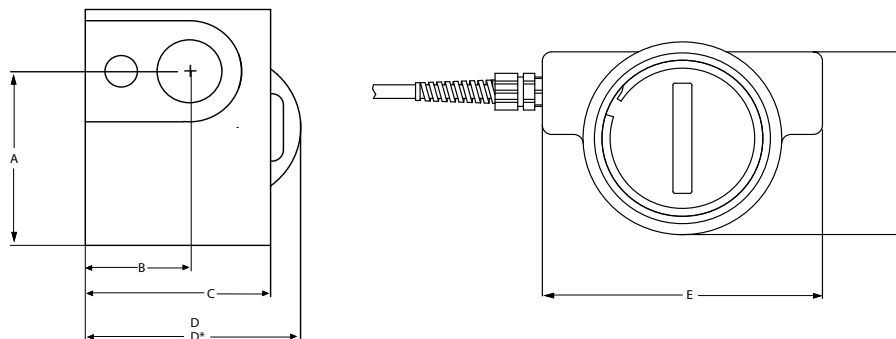

MECHANICAL DIMENSIONS

DIM	1/2" NPTF	3/4" NPTF - 1" NPTF
A	1.94" (49mm)	3.06" (78mm)
B	1.13" (29mm)	1.33" (34mm)
C	2.00" (51mm)	2.46" (62mm)
D	2.45" (62mm)	2.78" (71mm)
D*	2.45" (62mm)	2.88" (73mm)
E	3.70" (94mm)	5.25" (133mm)
F	2.63" (67mm)	3.80" (97mm)

*Dimensions with clear polycarbonate cover installed.

ELECTRONIC SPECIFICATIONS

4-20 mA version		0-5 VDC (regulated) version	
Power Requirements	12-24 VDC, Regulated, Loop powered	Power Requirements	12-24 VDC, Regulated
Load driving capacity	Use the following equation to calculate maximum load resistance: Max Loop Load (Ω) = 50 (Power supply volts - 12).	Maximum Current	25 mA DC, Regulated
Maximum Transmission Distance	Limited only by wire resistance & supply voltage	Minimum Load resistance	1000 Ohms
Response time	2 seconds to 90% (step change)	Maximum Transmission Distance	200 feet recommended
Resolution	Infinite	Resolution	Infinite
Over-current limit	Self limiting at 35 mA	Response time	< 5 seconds to 90% (step change)
Other protection	Reverse polarity		
Relay Output		Pulse Output Version	
Power Requirements	12-24 VDC, Regulated	Power Requirements	12-24 VDC, Regulated
Maximum Transmission Distance	200 feet recommended	Response Time	<100 mS
Switch Contact	Form C, 5A max 120 or 240 VAC	Maximum Current	25 mA DC, Regulated
Set Point Repeatability	1% of full scale	Maximum Transmission Distance	200 feet recommended
		Minimum Load Resistance	1000 Ohms
		Protection	Short circuit & reverse polarity
		K-Factor	1/2" port \approx 200 pulses/gallons 3/4" & 1" ports \approx 60 pulses/gallons

FLOWSTAT TURBINE FLOW SENSOR

Ideal for monitoring various fluids in applications such as chillers/cooling circuits, HVAC, medical equipment, batching and industrial process control applications.

PART NUMBER GUIDE

OUTPUT

- Current = C
- Pulse = P
- Relay = R
- Voltage = V

ROTOR COVER

- Clear Polycarbonate to 200 psi = C
- 316 Stainless Steel to 500 psi = S

PORT SIZE RANGE

- 1/2" NPT = B
- 3/4" NPT = C
- 1" NPT = D

MAX. FLOW RATE: GPM

- 1/2" NPT:
- 0.5 GPM up to 15 GPM Max. flow rates available =
- 3/4" & 1" NPT:
- 15 GPM up to 50 GPM Max. flow rates available =

**Important: Choose a maximum flow rate. For 1/2" NPT: 5-15 maximum GPM. For 3/4" and 1" NPT: 15-50 maximum GPM. Minimum flow rate will be 10% of maximum flow rate. Example: If your maximum flow rate is 8 GPM, the minimum flow rate would be .8 (8 x .1 = .8) Thus, the correct flow range would be .8-8.0 GPM.*

OPTIONS

- Control Cover = C
- Electronic Disconnect = D
- Low Flow Option** = L F

*** The low flow option will accommodate full-scale flow rates from 2.5 - 4.5 GPM for 1/2" only.*

COVER SEAL

- Buna-N (Standard) = B
- EPR (Optional) = E
- FKM (Optional) = V

TYPICAL PRESSURE DIFFERENTIALS

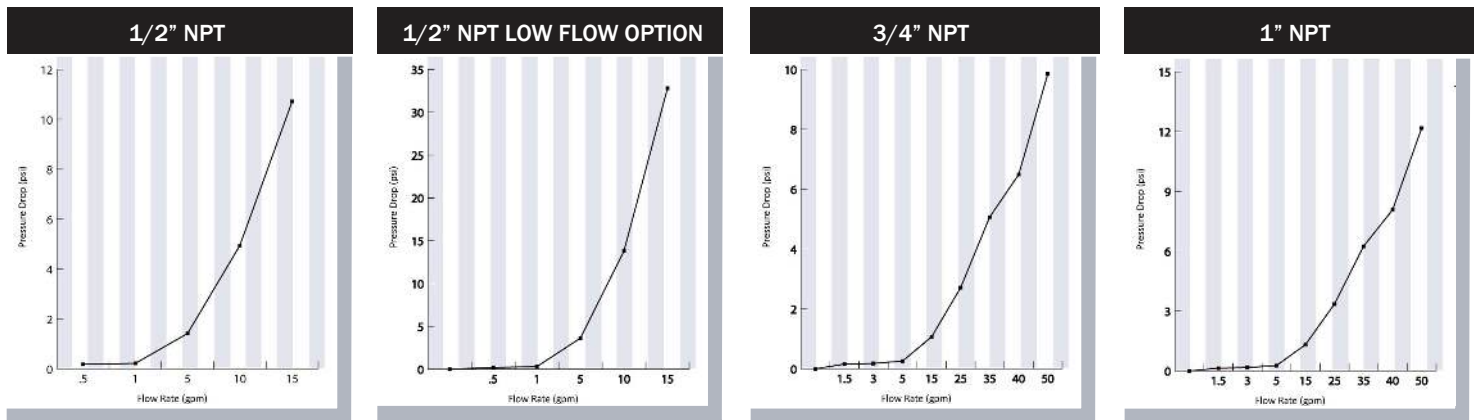

Products may be subject to change without notice - Contact factory for the most up-to-date product information.