

# RT-30Ex DUAL ACCESS HOUSING with HUB40 DIMENSIONAL DRAWING

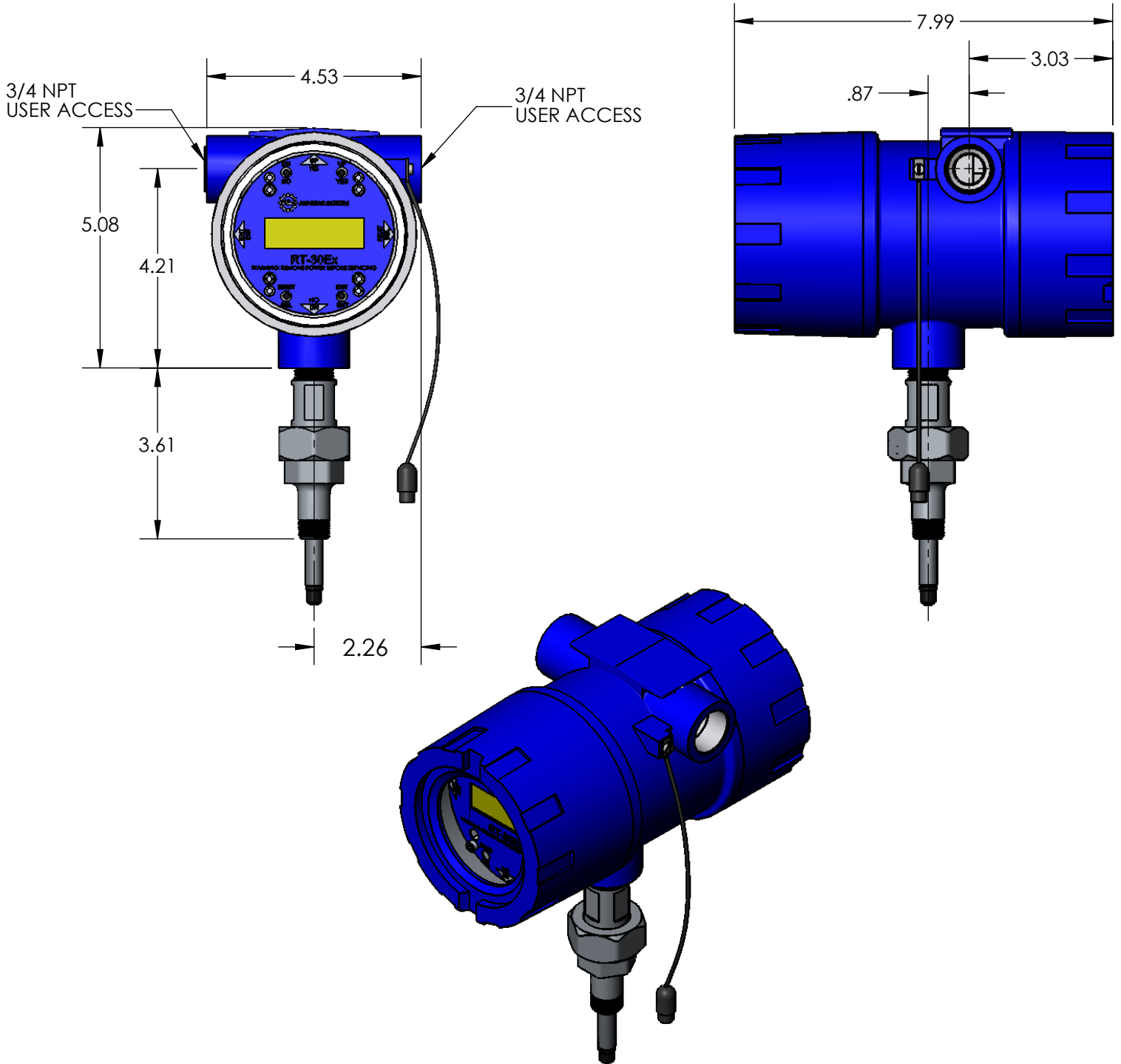

NOTE:

DIMENSIONS SHOWN ARE FOR REFERENCE PURPOSES ONLY

DRAWING NUMBER: RT-30Ex Dual Access Housing w\_HUB40(Dimensional Drawing)

<p style="text-align: center;">AW-LAKE COMPANY USE ONLY</p> <p style="font-size: small;">THIS PRINT, INCLUDING THE INFORMATION CONTAINED IN IT IS THE PROPERTY OF AW-LAKE COMPANY. IT IS CONSIDERED PROPRIETARY IN NATURE AND MAY NOT BE USED OR DISCLOSED OUTSIDE OF AW-LAKE COMPANY, EXCEPT UNDER PRIOR WRITTEN AGREEMENT. ANY MODIFICATIONS MADE TO OR COMMENTS WRITTEN ON THIS DRAWING BY UNAUTHORIZED PERSONNEL WILL VOID THIS DRAWING. ALL DIMENSIONS SHOWN ARE SUBJECT TO CHANGE WITHOUT NOTICE.</p>	<p style="font-size: small;">TOLERANCES UNLESS NOTED ENGLISH</p> <p style="font-size: x-small;">. XXXX +/- .0005 . XXX +/- .001 . XX +/- .01</p> <p style="font-size: x-small;">FRAC. +/- 1/64 ANG. +/- 1 DEG SURFACE FINISH: 64 MAX</p>	<p style="font-size: small;">PROJECT NAME:</p> <p style="font-size: small;">PART DESCRIPTION:</p> <p style="font-size: small;">MATERIAL:</p> <p style="font-size: small;">FINISH:</p> <p style="font-size: small;">HARDENING:</p> <p style="font-size: small;">PART NUMBER:</p> <p style="font-size: small;">DRAWN BY:</p> <p style="font-size: x-small;">PAGE: 1 OF 1</p>	<p style="font-size: small;">REV:</p> <p style="font-size: small;">DATE: 1/18/12</p> <p style="font-size: small;">SCALE: 1:3</p>	<p style="font-size: x-small; margin: 0;"><b>AW-LAKE COMPANY</b> A TASI GROUP COMPANY</p> <p style="font-size: x-small; margin: 0;">8809 INDUSTRIAL DR. FRANKSVILLE, WI 53126 TEL. # (262) 884-9800 FAX. # (262) 884-9810</p>
---	--	--	--	---

