

JV-UF Positive Displacement Gear Flow Meter

Common Uses

A completely new Series for AW-Lake, the JV-UF is designed for low viscosity fluids (solvents, scale inhibitor, methanol, DEF) in Stainless Steel bodies (303 and 316SS). We reduced the clearances around the gears to prevent fluid from slipping past and now measure flows as low as 0.0005 gpm with a 5cP fluid (we can measure fluids below 1.0 cP) and as high as 20 gpm. The JV-UF meters pair with our existing sensors to provide you with the data you need. Common applications include:

- Chemical, methanol, and fuel injection & dosing systems
- Test stands
- Hydraulic positioning systems
- Coolant & lubrication monitoring



Technical Specifications

5 Flow Ranges	0.0005 to 20 gpm (across all meter sizes)
Measuring Accuracy	±1.5% M.V. over full range (viscosity ≥ 5cP), ±0.5% M.V. optional with select sensors; ±2.5% M.V. over full range (viscosity ≥ 5cP) for JV-01UF
Repeatability	± 0.05%
Max. Operating Pressure	up to 6,000 psi
Ports	NPT standard, BSPP optional
Turndown	up to 500:1
Calibration	7-point calibration

Materials of Construction

Body	JVM = 303 Stainless Steel or JVS = 316L Stainless Steel
Gears & Bearings	Stainless Steel (DIN 1.4122)
O-Ring	FKM, FFKM, or PTFE
Shaft	402 Stainless Steel
Bolts	Zinc Flake Coated Carbon Steel (Inconel 718 optional)

Output Options

Choose from a wide variety of pickups, sensors, monitors, and controllers to pair with your gear meter:

- Frequency
- Analog (voltage or 4-20mA)
- Battery, loop, or DC powered displays

JV-UF Positive-Displacement Gear Flow Meter

Meter Data

Meter Size	Flow Range			Resolution*		Ports	Filtration (microns)	Pressure (psi/bar)
	(GPM)	(LPM)	(Gal/Day)	(Impulses/Gal)	(Impulses/CC)			
JV#-01UF	.0005-.25	0.002-1.0	0.72-360	302,600	80.0	1/4" NPT	15	5,000/345
JV#-12UF	0.005-0.8	0.02-3.0	7.2-1152	106,000	28.0	1/4" NPT	30	6,000/420
JV#-20UF	0.02-2.0	0.1-7.0	29-2880	31,800	8.4	1/4" NPT	30	6,000/420
JV#-30UF	0.1-7.0	0.5-25.0	144-10,080	13,200	3.5	1/2" NPT	30	6,000/420
JV#-60UF	0.1-20.0	0.5-75.0	144-28,800	3,600	0.95	3/4" NPT	30	6,000/420

- Complete part # by selecting body material as follows: M=303 Stainless Steel, S=316 Stainless Steel. * Figures shown represent resolution when using dual pickup sensor.

Meter Dimensions

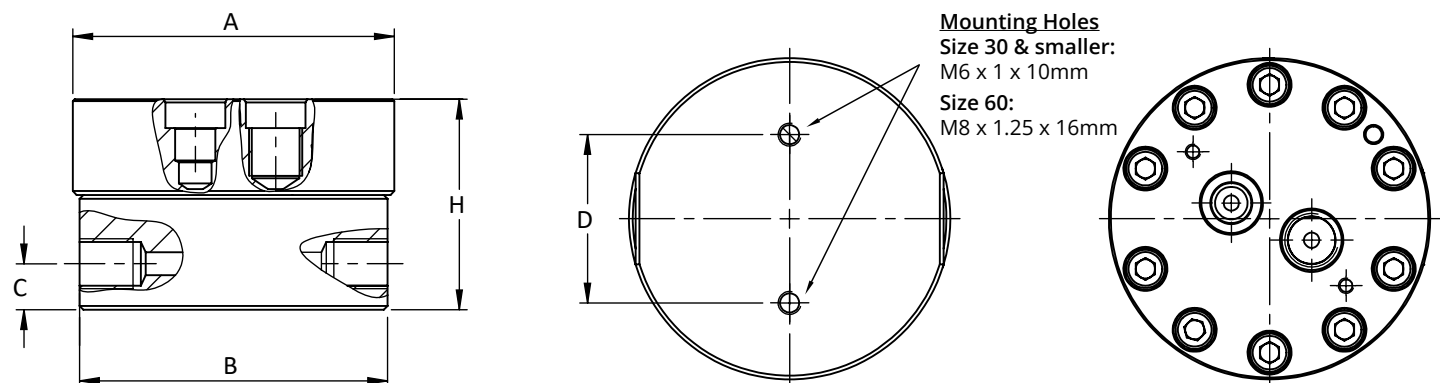

Meter Size	Dimensions					Weights (Lbs)		
	A	B	C	D	H	JVS	JVM	JVA
JV#-01UF	3.3"	3.2"	0.47"	1.7"	2.2"	3.6	3.6	1.8
JV#-12UF	3.0"	2.8"	0.47"	1.7"	2.2"	4.9	4.9	2.7
JV#-20UF	3.3"	3.2"	0.47"	1.7"	2.2"	6.4	6.4	2.9
JV#-30UF	3.3"	3.2"	0.59"	1.7"	2.6"	18.8	18.8	9.1
JV#-60UF	4.9"	4.7"	0.75"	2.4"	4.2"	78.0	78.0	32.0

3D STEP Models are available upon request of factory.
 Products may be subject to change without notice. Contact factory for the most up-to-date product information.

JV-UF Positive-Displacement Gear Flow Meter

Part Number Guide

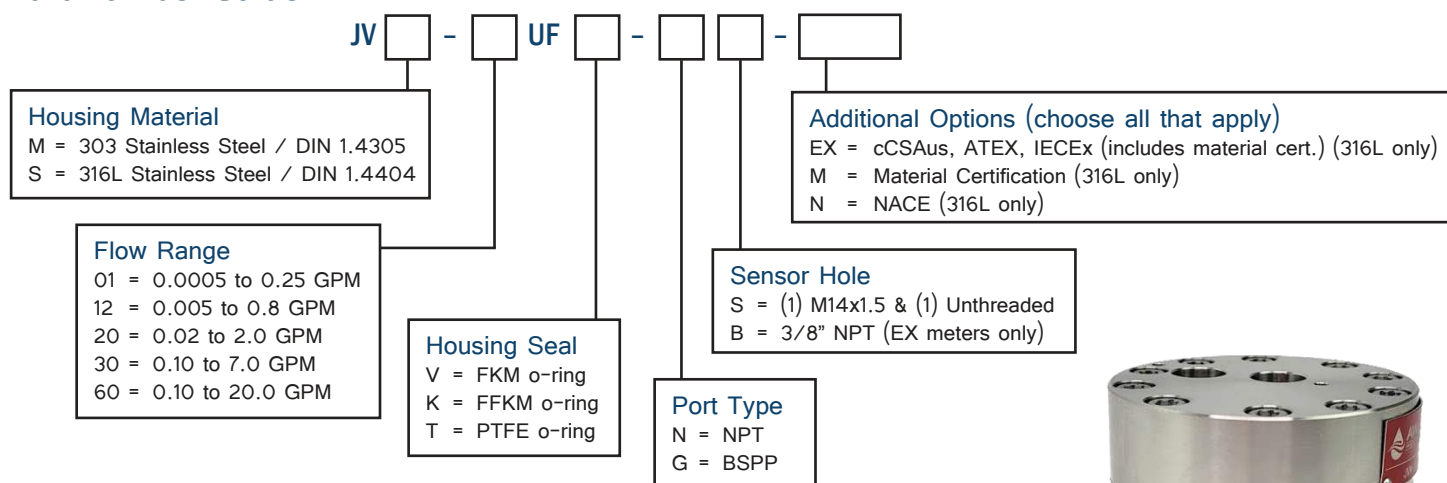

Recommended Sensors

AW-Lake offers a wide selection of Sensors/Pickups and Monitors/Controllers to optimize flow measurement and deliver your flow data where you need it and in the format you need it.

JV-UF Standard Sensor: EDGE Sensor

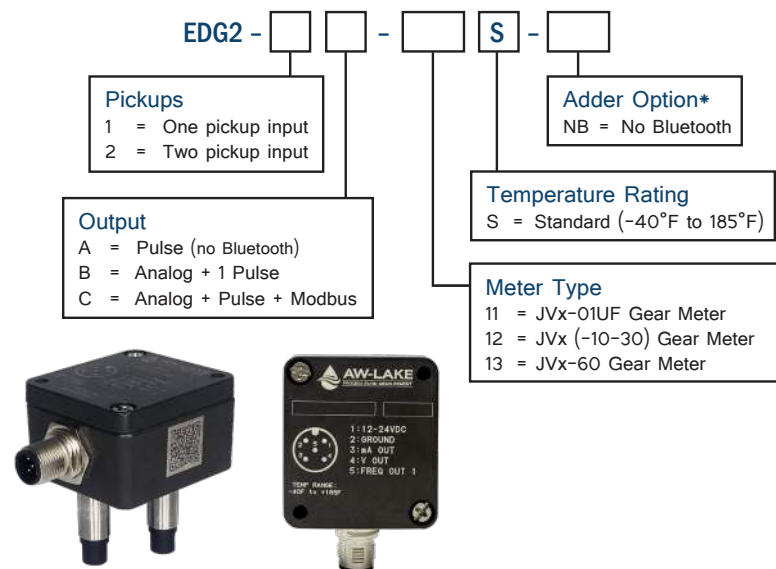

Additional Electronics Options:

JV-UF meters are also compatible with a range of other pickups, displays, and controllers for high temperature and EX-rated environments.

Visit AW-Lake.com for more information.



Products may be subject to change without notice.
Contact factory for the most up-to-date product information.